

MEDIATECHNOLOGYSYSTEMS INC.

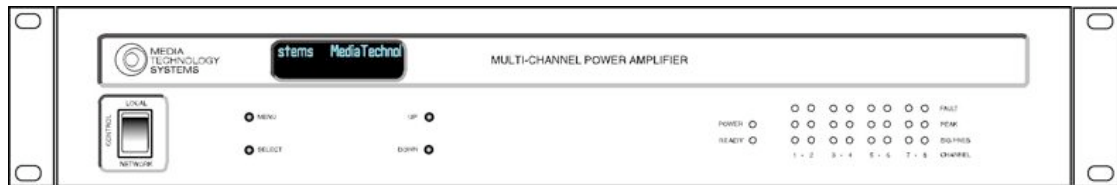

PROFESSIONAL MULTI-CHANNEL POWER AMPLIFIERS

PAG-Series
COM Series
AV-Series
SI-Series

5818 CALVIN AVENUE, TARZANA, CALIFORNIA 91356 U.S.A. www.mediatechnologysystems.com
Part # MAN-0308-MCA-RevB

FCC Compliance Notice & Interference Statement.

THIS DEVICE COMPLIES WITH PART 15 OF THE FCC RULES. OPERATION IS SUBJECT TO THE FOLLOWING CONDITIONS. THIS DEVICE MAY CAUSE HARMFUL INTERFERENCE. THIS DEVICE IS DESIGNED TO ACCEPT AND OPERATE WITH ANY INTERFERENCE RECEIVED. THIS INCLUDES INTERFERENCE THAT MIGHT CAUSE UNDESIRE OPERATION.

CAUTION: ANY CHANGES OR MODIFICATIONS MADE WITHOUT THE EXPRESS APPROVAL AND PERMISSION OF MANUFACTURER, VOID RESPONSIBILITY OF MANUFACTURER FOR COMPLAINE.

THIS EQUIPMENT HAS BEEN TESTED BY A COMPETANT BODY AND FOUND TO COMPLY WITH THE LIMITS FOR A CLASS-B DIGITAL DEVICE, PURSUANT TO PART 15 OF THE FEDERAL COMMUNICATIONS COMMISSION RULES. THESE LIMITS ARE DESIGEND TO PROVIDE REASONABLE PROTECTION AGAINST HARMFUL RF ENERGY IN A RESIDENTIAL INSTALLATION.

THIS EQUIPMENT, IF NOT PROPERLY INSTALLED IN ACCORDANCE WITH THIS MANUAL, LOCAL, STATE AND NATIONAL RECOMMENDED PRACTICES, MAY CAUSE HARMFUL INTERFERENCE TO RADIO COMMUNICATIONS. SUCH INTEFERENCE AND CAN BE DETERMINED BY SWITCHING THE DEVICE ON AND OFF. THERE IS NO GUARANTEE THAT THE DEVICE WILL NOT CAUSE INTERFERENCE. TO RADIO AND TELEVISION RECEPTION. USER IS ENCOURAGED TO TRY TO CORRECT ANY INTERFERENCE BY ONE OR MORE OF THE FOLLOWING MEASURES:

- RE-ORIENT OR RELOCATE THE RECEIVING ANTENNA*
- INCREASE THE DISTANCE OF ANY EQUIPMENT AND THE DEVICE.*
- CONNECT THE DEVICE TO A DIFFERENT A/C POWER CIRCUIT OUTPUT TO THE RECEIVER*
- CONSULT QUALIFIED TECHNICIAN OR A RADIO.TV SPECIALIST FOR ASSISTANCE.*

Explanation of Symbols



TO PREVENT ELECTRIC SHOCK DO NOT REMOVE COVER.
NO USER SERVICABLE PARTS INSIDE. REFER TO QUALIFIED
AND CERTIFIED SERVICE PERSONNEL. SMPS/PFC CARRY
POTENTIALLY LETHAL VOLTAGES.

CAUTION

**RISK OF ELECTRIC SHOCK
DO NOT OPEN**



The exclamation mark in a triangle is intended to alert the user to the presence of important operating and maintenance/service instructions in this manual.



The lightning flash in a triangle is intended to alert the user to the presence of un-insulated “dangerous” voltages with the product’s chassis that may be sufficient to create a risk of electric shock to humans.

Table of Contents

1	WELCOME	6
1.1	IMPORTANT SAFETY INSTRUCTIONS	6
1.2	DECLARATION OF CONFORMITY:	6
1.3	INTRODUCTION	7
1.4	HOW TO USE THIS MANUAL.	7
1.5	TERMINOLOGY: FUNCTIONS, NAMES & ACRONYMS.	8
1.6	MTSI MULTI-CHANNEL AMPLIFIER: MODELS/OPTIONS	13
1.7	AMPLIFIER SIGNAL PATH:	17
1.8	POWER SUPPLY DESCRIPTION:	20
1.9	AMPLIFIER POWER-UP SEQUENCE.	22
1.10	TIMING OF TURN-ON SEQUENCE:	23
1.11	INSTALLING YOUR AMPLIFIER:	24
1.12	SETUP	25
1.13	INPUT WIRE AND CONNECTORS:	28
1.14	OUTPUT WIRE AND CONNECTORS:	29
1.15	A/C MAINS POWER REQUIREMENTS:	30
2	CONTROL AND MONITORING	32
2.1	AMPLIFIER PARAMETERS	32
2.1.1	DATA FORMAT FOR EACH AMPLIFIER MODULE HOST PROCESSOR (MODULE 1, CHANNELS 1&2 SHOWN).	33
2.1.2	DATA FORMAT FOR RS485 PORT AND SMPS HOST PROCESSOR	34
2.1.3	ASCII FORMAT FOR AMPLIFIER MODULE HOST PROCESSOR	35
2.1.4	ASCII FORMAT FOR COMMS MODULE HOST PROCESSOR	36
2.2	METRICS	37
2.2.1	PRE & POST ATTENUATOR SIGNALS	37
2.2.2	OUTPUT CURRENT & VOLTAGE SIGNALS	38
2.2.3	TEMPERATURE	39
2.2.4	VOLTAGE RAILS	39
2.2.5	ATTENUATOR SETTINGS	39
2.3	V-BUS: RS485 CONTROL PORT PROTOCOL	40
2.3.1	ATTENUATOR SETTINGS	40
2.3.2	ASCII CODES	41
2.4	COMMUNICATION PROTOCOL	42
2.4.1	AMPLIFIER ADDRESS	42
2.4.2	TRANSMISSION CONTROL CODE	42
2.4.3	TIME LIMITATION	43
2.4.4	NUMBER OF RETRANSMISSIONS	43
2.4.5	TRANSMISSION BLOCK	43
2.4.6	COMMON FORMAT	44
2.4.7	POLLING BLOCK	44
2.4.8	SELECTING BLOCK	44
2.4.9	DATA BLOCK	45
2.4.10	ACKNOWLEDGE	45
2.4.11	NEGATIVE ACKNOWLEDGE	46
2.4.12	BCC CALCULATION	46

2.5	COMMUNICATION SEQUENCE	47
2.5.1	POLLING SEQUENCE	47
2.5.2	ASCII CODES	ERROR! BOOKMARK NOT DEFINED.
2.6	2.6 AMPLIFIER COMMAND FORMAT	53
2.6.1	AMPLIFIER DIP SWITCH SETTINGS	53
2.6.2	AMPLIFIER ADDRESS NUMBER	54
2.6.3	AMPLIFIER COMMAND NUMBERS	54
2.6.4	AMPLIFIER SELECTING SEQUENCE (WRITE)	55
2.6.5	AMPLIFIER SELECTING SEQUENCE (READ)	55
2.6.6	AMPLIFIER COMMAND SET (SLAVE MODE)	57
2.6.7	ATTENUATION WRITE COMMAND	58
2.6.8	CONTROL WRITE COMMAND	59
2.6.9	ATTENUATION READ COMMAND	59
2.6.10	CONTROL READ COMMAND	61
2.6.11	STATUS READ COMMAND	62
2.6.12	TEMPERATURE READ COMMAND	64
2.6.13	SIGNAL READ COMMAND	65
2.6.14	GLOBAL READ COMMAND	67
2.7	AMPLIFIER COMMANDS (AMPLIFIER AS MASTER)	70
2.8	HARDWARE INTERFACING	70
2.8.1	RS485: BASICS	70
2.8.2	MTS AMPLIFIER PINOUT	73
2.8.3	V-BUS MONITOR SOFTWARE	73
3	NETWORK AMPLIFIERS	82
3.1	COBRANET	83
3.2	SNMP	83
3.2.1	COBRANET OID'S	83
3.2.2	DSP EXTENSIONS	83
3.2.3	MTS AMPLIFIER EXTENSIONS	86
3.3	ETHERNET	88
3.3.1	TELNET	88
3.3.2	ETHERNET GUI	88
4	AMPLIFIER VACUUM FLUORESCENT DISPLAY	98
4.1	COBRANET STATUS	98
4.1.1	COBRANET COMMUNICATION STATUS	98
4.1.2	CONDUCTOR STATUS	99
4.1.3	SERIAL PORT OPTIONS	99
4.1.4	COBRANET ERRORS	100
4.1.5	INTERFACE FIRMWARE	100
4.2	BUNDLE ADDRESSING	101
4.3	IP ADDRESSING	101
4.4	SIGNALS	102
4.4.1	INPUT SIGNALS	102
4.4.2	OUTPUT SIGNALS	102
4.5	AMPLIFIER SETTINGS	103
4.5.1	GAIN	103
4.5.2	TEMPERATURE	103
4.5.3	MUTE & FAULT STATUS	103
4.5.4	HPF & BRIDGE SETTINGS	104

1 Welcome

1.1 Important Safety Instructions

- Important Safety Instructions:
- Read these instructions.
- Keep these instructions.
- Heed all warnings.
- Follow all instructions.
- Do not use this apparatus near water.
- Clean only with dry cloth.
- Do not block any ventilation openings. Install in accordance with the manufacturer's instructions.
- Do not install near any heat sources such as radiators, heat registers, stoves, or other apparatus (including amplifiers) that produce heat.
- Do not defeat the safety purpose of the polarized or grounding-type plug. A polarized plug has two blades with one wider than the other. A grounding type plug has two blades and a third grounding prong. The wide blade or the third prong is provided for your safety. If the provided plug does not fit into your outlet, consult an electrician for replacement of the obsolete outlet.
- Protect the power cord from being walked on or pinched particularly at plugs, convenience receptacles, and the point where they exit from the apparatus.
- Only use attachments/accessories specified by the manufacturer.
- Unplug this apparatus during lightning storms or when unused for long periods of time.
- Refer all servicing to qualified service personnel. Servicing is required when the apparatus has been damaged in any way, such as power-supply cord or plug is damaged, liquid has been spilled or objects have fallen into the apparatus, the apparatus has been exposed to rain or moisture, does not operate normally, or has been dropped.

1.2 Declaration of Conformity:

TBA.

1.3 Introduction

The Media Technology Systems Series of multi-channel power amplifiers are professional products specifically designed for Systems Integration, Commercial, Industrial applications. To get the maximum performance from your product, please read and study the contents of this manual.

Features: MTSI amplifiers are sophisticated products designed for their applications using many decades of accumulated experience in all areas of design, manufacture, and an understanding of final use and abuse of these products.

In large installations, power usage is a significant consideration. MTSI multi-channel amplifiers all feature SMPS with PFC and Class-D output stages, to maximise efficiency and space. The amplifier family consists of 4 ranges with different functions and applications:

COM: Communications Series: 70/100V networked & Control & Monitoring, amplifiers
Si: Systems Integrator Series: 4/8 Ω
PAG: Paging Series: Basic 70/100V amplifiers
AV: Audio/Visual Series, 4/8 Ω amplifiers

The specifics of each of these model series will be covered in this text. Since much of the basic functionality of these amplifiers is common, this manual is designed to cover the complete range. Take care to refer to the text for specific details or differences between models.

Each MTS multichannel amplifier features Power Factor Correction, a Switch Mode Power Supply and Class-D output stages, for maximum efficiency, cool operation and consistency of performance on any A/C power.

These amplifier series are designed for a number of different system uses and vary in sophistication and specification according to the demands of each application

1.4 How to use this manual.

This manual provides you with valuable information for safely and correctly installing, setting up and operating your amplifier. It is not possible to cover all aspects of installation and application of complex product. However, we have attempted to supply all critical and essential information, plus advice and explanations where relevant. There is a great body of work re amplification and sounds systems best practices, available from many sources on line. MTSI will, from time to time add "White Papers" and Application Notes to our website. As well as additional information on amplifier use and other valuable information.

It is particularly important that you read this manual and especially the Warnings and Cautions.

1.5 Terminology: Functions, Names & Acronyms.

Attenuation/Attenuator: An attenuator is used to reduce the level of an incoming signal. Many think the "volume" control on typical audio equipment makes the power of the amplifier greater. In fact amplifiers are typically pre-set with a specific amount of gain. The input attenuator or volume control is used to vary the amount of signal that is allowed through to the amplifier's gain section.

BGM - Back Ground Music: Typically low-level ambient music such as one would find in an elevator or super-market.

Bridge Mode: Bridge mode allows the installer to configure two amplifier channels to drive one given loudspeaker load with four times the power than either of the single amp channels alone. There are important factors and considerations to understand when using this mode of operation. In effect two amplifiers are driven out of phase with each-other and their output connections are made to work in push-pull mode on each side of the speaker plus/minus load connection. In bridge mode, a nominal 8 Ω loudspeaker "looks" to each of the two amps connected, like a 4 Ω load. For example: A two channel pair of amplifiers with 300 Watts capability each into 4 Ω can now deliver 600 Watts into an appropriately rated speaker load of 8 Ω . Normally one 300 Watt into 4 Ω amp can only deliver 150 Watts into the 8 Ω load. But using Bridge Mode, we can now power the same loudspeaker to 600 Watts should it be required and the speaker rated for that power level.

Note: 70/100 Volt amplifiers are not "bridge mode" capable.

Do Not Use 2 Ω or 4 Ω loads across a bridged output pair. The minimum impedance usable is 8 Ω . It should be understood that in this mode, each of the amplifiers in the bridged pair is looking at half the total speaker load impedance. Thus an 8 Ω load actually presents the minimum 4 Ω load to each amplifier in the pair.

Class-D Amplification: A switching amplifier or class-D amplifier is a electronic amplifier where the active devices (especially in the output stage) are operated as on/off switches. Class-D amplifiers have the potential to provide audio power at higher efficiencies that alternative methods further increasing the efficiency of the systems and valuably reducing wasted energy dissipated as heat.

Amplifier efficiency vs Loudspeaker efficiency. Class A-B amps are typically around 40% or so, class-D can be much higher. 100 Watts of input power gives you 40 Watts of audio electrical power and 60 Watts of heat. See above. It should be noted that loudspeakers are a completely different order of transducer. The best and most efficient single woofer available anywhere on the market today has only around 2% efficiency! For every 100 Watts we push into that speaker only 2 "acoustic" Watts of audio (Sound Pressure Level) is produced, with 98 Watts coming out as heat. And this example uses the highest efficiency speaker! Typical home stereo speakers may convert electrical power into SPL at 0.1% or worse. Electrical power not converted into "work"

moving the piston, must be dissipated as heat. Heat is the great enemy of loudspeakers and as you can understand, there is a lot of heat to get rid of. Speakers are not particularly good at venting this waste heat, particularly when driven at high levels for long periods. Damage or failure is often the result of poorly chosen or designed systems. It is advisable to check the speaker manufacturer's data, in particular the power compression numbers. Power Compression is a phenomena where the heat build up in a speaker's voice coil raises the impedance of the coil from its nominal or spec'd level to sometimes double or more. Thus an 8Ω load, under high sustained levels, can easily turn into a 16Ω load with the result of having half the efficiency. This requires double the level of drive power to make the original desired sound pressure level, and so on downwards in a spiral and burn-out as the operator increases the power to get back to the desired levels. The better the loudspeaker the better its ability to convert electrical energy into "work" =output and the less heat dissipated. The better the loudspeaker design the better its ability to dissipate heat without damage. Larger voice coils, proper top-plate and gap design, air flow, high temperature materials, etc., all provide improvements, but cost more money to make. Good system design and anticipation of the performance demands, with sufficient numbers of loudspeakers for coverage and power can make the difference between a poor and unreliable system and a great system for the customer's needs.

CMRR: Common Mode Rejection Ratio, is the ability for an input circuit to reject noise interference and other artefacts induced on the input signal lines. A balanced line, or differential input has two, opposite and equal, plus and minus, input connections and a centre ground reference. The cable has two conductors and a shield or ground connection. At the transmit/send/source end of the cable the audio signal is split and one side is inverted in phase. Over a run of cable any hum, buzz or other electromagnetic interference, not effectively shielded by the cable is picked up and theoretically induced equally on both the plus and minus conductors. Thus we have the intended signal running out-of-phase and any induced noise running in-phase across the two conductors. These opposite and equal signals are brought into a differential amplifier where the phase of one of the signal that was inverted is put back into phase and the two signals added together. The signals since they are complementary add together. The noise which was in phase is inverted added together but now out of phase and thus cancelled. The instrumental Instrumentation input is of the highest quality where the circuits and values of the components are closely matched. The more closely matched the two sides of the input are the greater the ability of the circuit to reject and common mode signals.

CobraNet®: CobraNet is a proprietary digital audio networking protocol designed for high quality, low latency digital audio transmission. <http://www.cobranet.info/en/>

COMMs Board: MTSI designation for the Communications Module that manages internal communications and external interface, control etc.

D.C. A Direct Current offset on the speaker terminal of more than +/-5v DC.

DEGSON: The 'Degson' -type connector is a pair of high current, latching, output connectors used for speaker and 70/100V Line loads. Rated at 300V/15A these connectors are reliable, of high quality, and simple to install and re-configure.

Fault: The LED when illuminated indicates a fault has occurred in one of the amplifier modules which has triggered the automatic protection circuitry to suspend operation of that channel. There are automatic sensing circuits in the amplifier that constantly monitor and re-check circuits. Should the fault condition continue for some time, disconnect the signal input and the speaker-load and re-cycle the power switch. If the fault condition continues, refer to a qualified and MTSI approved service technician.

Hi-Pass Filter – HPF: A High Pass Filter is used to roll-off or attenuates signals below a selected frequency. For example a 100 Hz HPF with a 6dB per octave roll-off characteristic will have a nominal response that is -3dB at 100 Hz from the normal flat bandpass, and will be -9dB down at 50 Hz. A 12dB per octave filter is double that of the 6dB type. In an amplifier the HPF is classically used to limit the power an amplifier is asked to supply at low frequencies. Typically distributed loudspeakers and many Voice Coil loads used for voice, paging and BGM do not require low frequency content below 100 - 120 Hz. These loudspeakers are designed for speech frequency range efficiency and optimized in the system for power and

LAN -Local Area Network: A digital network normally using CAT-5/RJ-45 or WiFi connectivity for routing data, and digital audio and video signals

Latency: Effectively the difference in the time delay of a signal from send to receive. Low latency is considered in the 2ms to 12ms range. Above the 12ms latency the delay between an original signal and the reproduced signal becomes perceptible and detracts from the intelligibility of the communication. Note: In paging applications latency is not an issue since there is rarely "open-microphone" use as in entertainment or other "Live" uses.

Local-Network: This front panel switch selects local or Network control of amplifier functions. In "Network" mode, the amplifier is controlled through, for example, a computer connected to the amplifier control input on the rear panel. In the "local" mode the amplifier's DSP functions and power on sequence are controlled by the VFD display and the internal power up circuits respectively.

Module Micro: This board is fitted to each two channel amplifier module of networked and Control & Monitoring series amplifiers. It provides networked series amplifiers with remote VCA control for level and gain, metrics gathering and transmission and other amplifier board automation and communications.

Multi-channel Mode: In two channel amplifiers the word Stereo is often used to describe Left and Right, or separate multi-channel mode. Since MTS amplifiers are available from 2 to 8 channels in 2 channel increments, we will use the term – multi-channel.

Peak: The LED when lit indicates a high level signal is present at the amplifier's input. Caution should be exercised since signals at this level are close to, or are clipping the amplifier. Occasional peaks are acceptable. Constant peak indication should prompt a review of the system and its use demands. MTSI amplifiers have graceful overload characteristics which progressively, rather than catastrophically clip.

Load Condition: A mismatched load such as a short circuit load or non-standard low impedance load.

Phoenix/Euro Type Connector: Phoenix-type 3 circuit connectors are used for audio signal input to the amplifier channels. Input impedance is 20k Ω balanced, 10k Ω unbalanced.

Power: The Power LED when lit, indicates power is applied to the unit.

Power Factor: The power factor of an AC electric power system is defined as the ratio of the real power to the apparent power, and is a number between 0 and 1. A pure resistive load has a PF of 1. Real power is the capacity of the circuit for performing *work* within a particular time. Apparent power is the product of the current and voltage of the circuit.

Power Factor Correction: A PFC provides the means of increasing the power factor within an electrical system and therefore its efficiency. It can be an active or passive input circuit that changes the power factor of the input current to a device so that it is closer to a Power Factor of 1.0. Numerous benefits include reduced input line current and lower input harmonics. It is also a technique for counteracting the undesirable effects of electric loads that create a power factor (p.f.) that is less than 1 (one). In commercial applications with the potential for multiples of amplifiers required for emergency paging where life could be at risk, (UPS) uninterruptable power supplies are often used. The size and cost of these battery backup systems is reduced when the efficiency of the powered items is improved. Additionally power saved is beneficial to the operating costs of a facility as well as the environment.

RS-485: An IEEE standard protocol for signal distribution.
<http://en.wikipedia.org/wiki/RS-485>

Signal Present: The LED illuminates with the presence of a low level signal at the amplifier's input. This is a useful feature for visually confirming signal flow to this point in a sound system.

SMPS: Switch Mode Power Supply, is a type of power supply topology, which takes the incoming potential energy from the A/C power line and "chops" it into very short pulses. In the MTSI series amplifiers, we use an SMPS frequency of 100KHz. Normal Linear Power Supplies use the incoming A/C wave form (typically 50 or 60 Hz and either 120V or 240V) and rectify the energy into DC, which is stored in the supply capacitors. This is a PFC - Power Factor Corrected

Standby LED: This LED illuminates when the amplifier is held in a non-operational state. When un-lit, the amplifier is on-line and ready for use within 3 seconds.

Termination-1: Commonly use term for connecting input and output cables.

Termination-2: In the networked and control & monitoring amplifiers, the RS485 connector is provided with a "termination" selector switch to apply a 150 Ω resistive

load to the I/O. This is often used to “load” the TX/RX driver. Check the requirements of the interfacing device and select the appropriate setting.

Thermal: heat-sink temperature has reached 75 deg C.

VFD: Vacuum Fluorescent Display: A vacuum fluorescent display is a high quality, bright and easily read display used in these products to display operational and communications data. This more expensive type of display was chosen for its ability to be read at a distance.

1.6 MTSI Multi-Channel Amplifier: Models/Options

PAG-Series: The PAG Series of modular power amplifiers are designed of application to Paging applications using 70 or 100 Volt Line, constant voltage distribution system. Prior to powering the amplifier select either 70 or 100 V on the mode selector beneath the AC power switch. At power up the PAG amplifier will configure its SMPS/PFC supply to provide the appropriate rail voltages and gain settings for this type of operation.

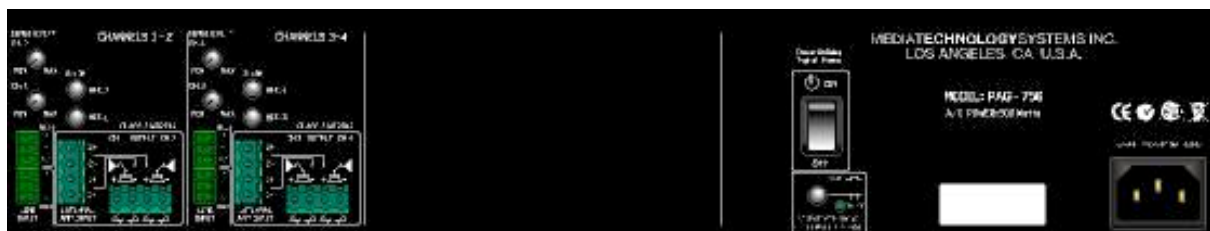

AV-Series: AV Series Multichannel power amplifiers are designed for application to low impedance, 4, 8 and 16Ω direct loudspeaker loads. The minimum nominal load impedance on all this series is 4Ω.

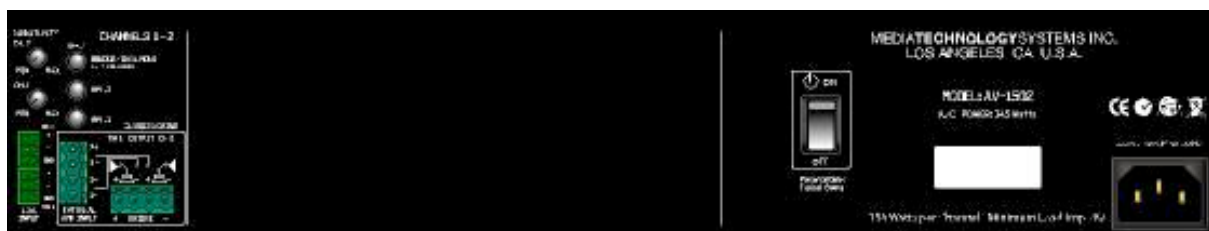

COM-Series. Commercial Series amplifiers are 70 or 100Volt line amplifiers primarily intended for applications where long runs or high multiples of speakers are distributed within an installation.

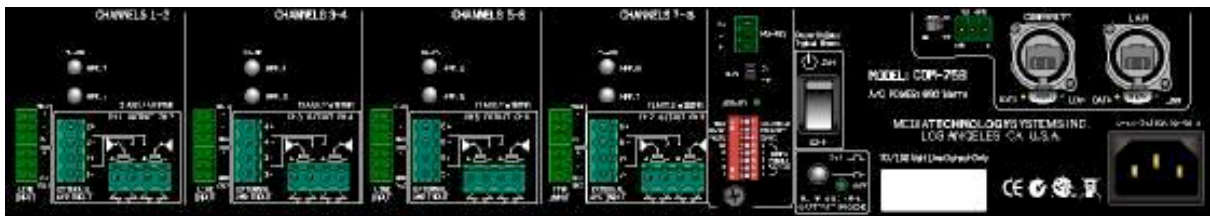

Si-Series: Systems Integration amplifiers are 4 and 8Ω direct loudspeaker load amplifiers, for foreground and background music and other shorter run audio system use.

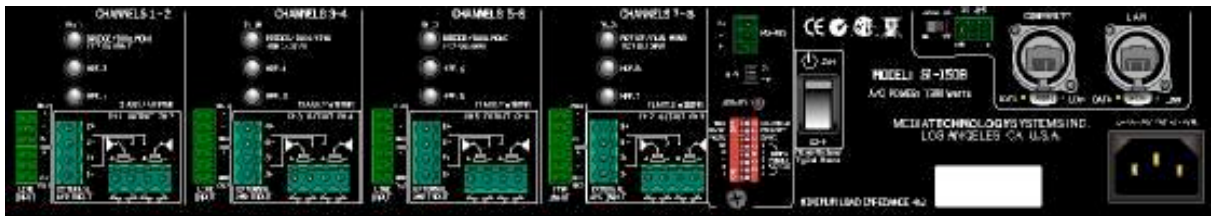

1.7 Amplifier Signal Path:

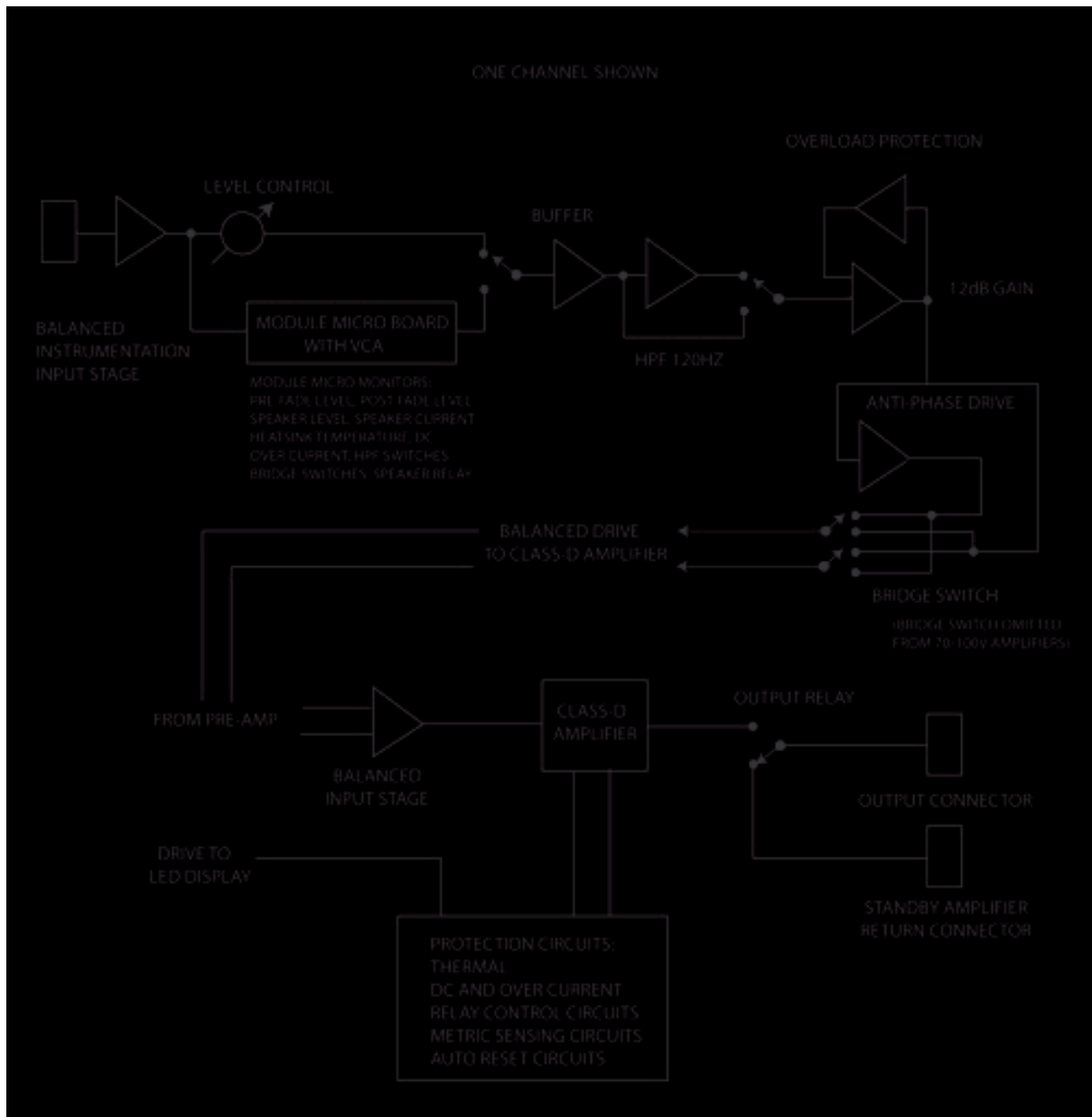

This description refers to one channel of a power amp module. Note: MTS amplifiers are constructed using two channel amp modules. Depending on the output power required, the chassis may be configured for up to 8 channels with a maximum “chassis” total audio output of 2400w.

For example:

8 channels. 4 of any 2 channel module of 75, 150 or 300W per channel.

4 channels. 2 of any 2 channel module to a maximum of 2 dual channel 600w modules.

2 channels. One of any two channel module up to a maximum of 1, dual channel 1,200 watt module.

Signal Flow: A balanced analog signal is fed into each 3.5mm three pin input socket. (unbalanced connections may be used, but depending on signal levels, the risk of noise interference is significantly increased) Please refer to the section later in this manual where a full description is available on how to connect to the various ports on the rear panel of the amplifier.

The incoming audio signal is routed through a fully balanced *instrumentation amplifier*. This vastly superior input circuit, outperforms the simple single op-amp type used by most manufacturers, greatly improving CMRR and providing superior rejection of unwanted ultra sonic signals.

The output of the instrumentation input stage is converted to a single ended signal for further processing through the module.

After the input stage, a switch selects the routing through either a passive trim potentiometer (in basic amp models) or through the Module Micro.

In Control and Monitoring and Networking amp models, the signal may be controlled by a VCA (Voltage Controlled Amplifier). For applications requiring higher gain where there might not be an external pre-amps, such as in some paging situations, an additional 12dB of gain is available at this stage. The VCA is part of the Module Micro Board, which is fitted to all control and monitoring and networked models, where its primary function is to sense and communicate all important parameters and conditions within EACH channel of amplification.

The following functions are performed and monitored by the Module Micro processor board:

1. Module Signal Gain, when this card is used an extra 12dB of voltage gain is available.
2. Input Level Control.
3. Post fader level control
4. Speaker output voltage monitoring
5. Speaker Current: (through monitoring this data the connected computer can calculate instantaneous power. Since program signals are stochastic and loudspeakers represent highly dynamic elements in the system, smoothing or averaging is desirable for information to be of any value. This function is the job of the monitoring computer program. MTSI supplies the raw data rather than interpreting anything so)
6. Heat sink temperature.
7. Speaker relay control .
8. The position of the HPF and bridging selectors is monitored. (not available on 70/100v line type modules). The operator may check the settings of the physical switches by viewing their status on the computer console.
9. Protection: If an amplifier channel exhibits a DC offset of greater than 5v on the speaker terminal.
10. Protection: If the output current has exceeded a safe value for that particular type and power rating of the amp module.
11. Individual amplifier channel speaker relays may be turned opened or closed by the operator.

Standby Amplifier Connection: Each amplifier output channel features an additional special input to which the output of a Standby Amplifier may be connected. In the unlikely event of a faulty amp channel, the amp's protection circuits automatically lift the connection from the internal amp to its normal output. At the same time, the relay connects the incoming 'Standby Amplifier' through the speaker relay terminals, to the original speaker load. (Any other channel or amp may be used as backup/standby, even one in the same chassis. However, for complete redundancy it is advisable to use a completely separate Standby Amplifier chassis.)

An internal selector switch bypasses the Module Micro and selects between "simple" or micro processor mode. This switch is NOT user accessible.

The signal is passed through a unity-gain buffer which assures a low impedance drive for the High-Pass filter section. The switch selectable HPF is 12dB per octave, Butterworth response with its -3dB point at 120 Hz.

The final pre-amplification stage contains a 12dB gain section, a balanced drive stage and an over drive compressor which prevents any possibility of amplifier clipping. This final protection limiter is set well above the normal linear signal levels required to give the rated power any the specific amplifier and thus does not interfere or create any audible change in a normal signal. Only under catastrophically high input levels, where severe clip would be apparent, does the limiter/compressor come into effect.

Loudspeakers can handle surprisingly high, short term-transient overdrive signals but are easily damaged by high levels of amplifier clipping. The limiter/compressor thus provides additional protection for the loudspeakers from misuse and abuse.

The signal flows to the Bridge Switch (not available in the 70/100v modules) which allow those 4/8Ω or "voice coil" modules to be operated in bridge mode.

NOTE: When operated in bridge mode, each channel of a bridged pair of amps "sees" 50% of the total load impedance it is driving. Thus a 4 Ω speaker load presents a 2 Ω load to each of the bridged pair of amplifiers. Since this is below the rated output impedance of the amplifier(s), caution must be exercised when connecting any speaker load to a bridged pair of amp channels. Check and confirm that the load is within driveable parameters.

Line type (70/100v) modules have a control buss and sensing which automatically changes the control & monitoring metrics and control circuits to suit each different model, as well as the adjusting the overall gain structure of the amplifier. 100v operation requires +3dB more gain over 70V. This function keeps the input sensitivity at -8dB whether the amplifier is in 70 or 100v mode.

The balanced signal is fed to a balanced input stage which then drives the Class-D power amplifier. The output of each channel is fed through the contacts of a high current speaker relay which performs two functions. Firstly it facilitates the option of using of an external standby channel amplifier (see above) and secondly performs muting duty holding the relay open until all internal sensing and management determines the system is performing to spec and is stable.

Should for any reason, a channel's heat sink temperature reach an unsafe level (>70 deg C), the speaker relay is disengaged and the load is 'lifted'. The relay will automatically re-engage once the heat sink temperature as dropped to a safe level.

An over-current condition will trigger two protection circuits. Firstly the Class-D amplifier is shut down virtually instantaneously (1/400,000th of a second) and secondly the speaker relay is disengaged. These actions prevent damage to the Class-D amplifier and the load. An auto-reset circuit will re-engage these functions after about 5 seconds. If the fault condition still exists the process is repeated until it is corrected.

The LED display is driven from each module. The Signal Present, green LED displays (as you'd expect!) the presence of a low level signal at the input. The red LED displays signal peaks which approach the maximum output of a channel. The amber LED displays a fault condition.

1.8 Power Supply Description:

All MTS amplifiers use a Power Factor Corrected (PFC) Switch Mode Power Supply (SMPS). This type of supply has several advantages over their linear counterparts. Firstly the power supply conforms to new regulations , either proposed or in place in certain countries, which demand that any supply over 70 watts be a PFC type. An ideal PFC supply is "seen" by the A/C mains supply – wall socket, as a pure resistive load. MTS amplifiers achieve a high and close to theoretically perfect power factor in excess of 0.99. Last the supply draws less current from the AC supply saving the consumer expense over the life of the amplifier.

Importantly, MTSI has designed the SMPS so there is no need for a voltage selection switch. Since the amplifier will work on any nominal A/C mains input from 85 to 265 Volts and at any A/C frequency from 47-63Hz. Thus these amplifiers will deliver full rated power on virtually any input voltage even when 'brown outs' or poor stability can shut down or severely reduce required output power, in other less sophisticated products.

The A/C mains enters through a standard IEC connector, then a fuse and then a DPST power switch. For reliability this switch is designed with 100 amp surge capability even though the normal turn on surge is less than 0.5 amp. Next, an EMI/RFI filter blocks the transmission of interference back into the mains supply maintaining 'clean' power in the system for low system noise.

Micro processor versions of MTSI amplifiers require that the sensing and management circuits are kept active as long as the power switch is turned on, allowing the amplifier to be turned on by remote control.

We employ an additional low level SMPS power supply to power the CobraNet®, Module Micros and Comms Board. This SMPS also provides start up voltages to get the main supply up and running.

POWER SUPPLY SCHEMATIC

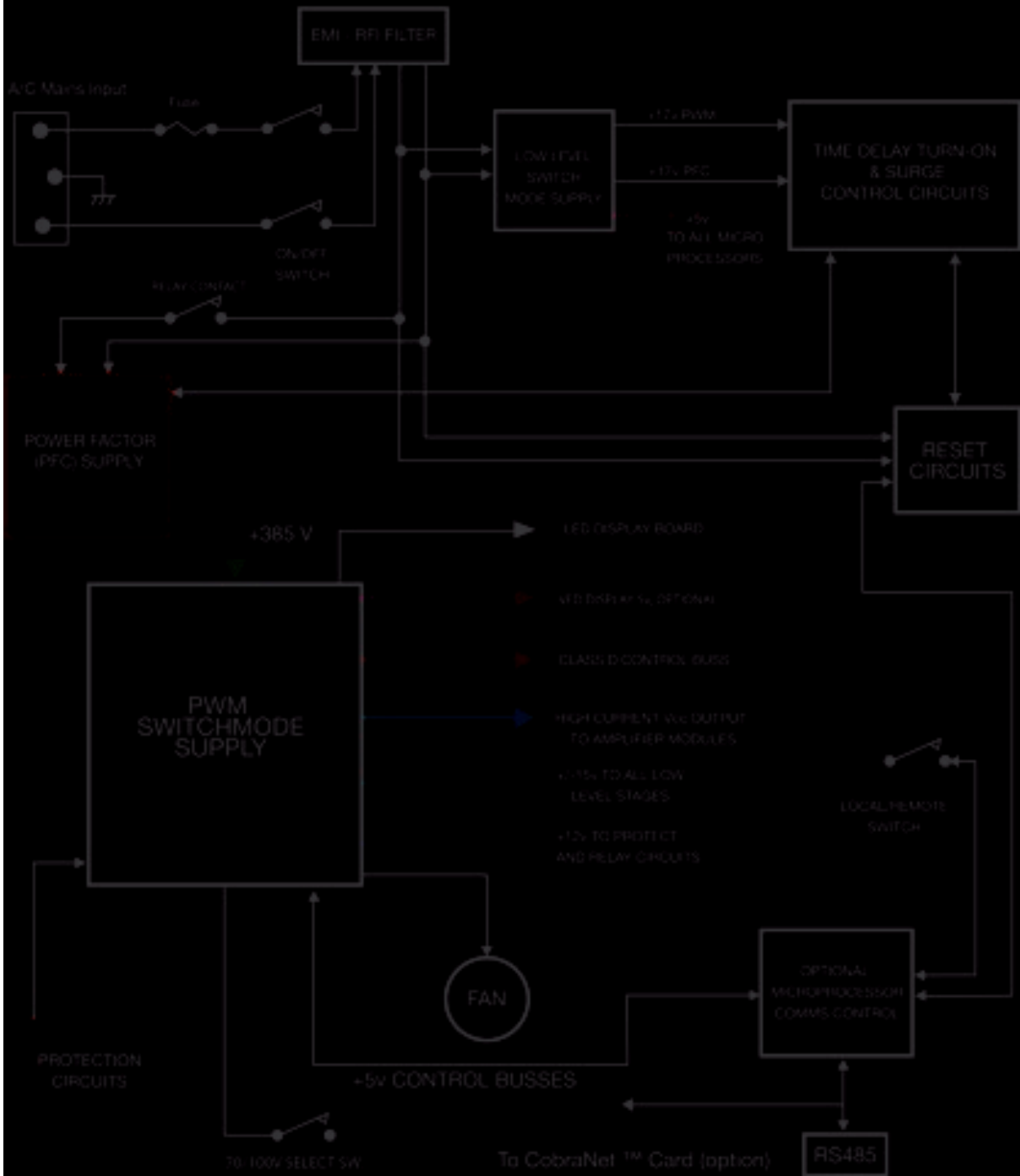

1.9 Amplifier Power-up Sequence.

The Media Technology Systems multichannel power amplifier family consists of four basic series, varying from basic amplification to fully networked, CobraNet, control and monitoring products. Within these sophisticated products are a number of components and subsystems. For proper operation, a timed and monitored sequence of events takes place in which power supplies and circuits are activated. This section describes this turn on sequence and timing.

There are six power supply systems within the amplifier.

All microprocessor circuits and the (optional) Cobra card are powered by a high current 5 Volt supply.

The main pulse width modulator control section, which itself controls the main switch mode supply, operate on low current supplies.

Another low current supply feeds the control circuits for the Power factor Corrector.(PFC)

A fully regulated 12 Volt supply feeds all control relays and protection circuitry.

Two regulated +/-15 Volt supplies feed all low-level analog audio stages.

Class-D amplifier stages are driven by the main high voltage, high current supplies.

The order and timing in which these supplies and circuits are activated is critical to the correct operation of the amplifier.

When A/C power is applied by turning ON the rear panel power switch, the small SMPS supply is energized. At this time the main supply is off. The main PWM switch mode section is activated and is dependent on the peak value of the A/C mains input for its initial operation. At this time it is not ready for normal operation. After a TWO second delay, the PFC is activated which then allows the PWM section to deliver its required voltages. In another TWO seconds the surge suppression circuits are bypassed. The power supply is now ready to deliver current to the various circuits throughout the amplifier.

However, the amplifier is not yet ready to go into full operation. Firstly the Class-D outputs are held off, until the main supply is fully activated. When stable, the Class-D control buss is turned on and with it, the Class-D amplifiers. An additional wait of approximately TWO seconds allows the amplifier to intelligently check and confirm all parameters are correct and only then close the output speaker relays.

The MTSI amplifier is a sophisticated 'system' in one box, with many functions and parameters needing to be confirmed before the next stage can be activated. Conditions such as A/C power, in-rush current, temperature, etc., need to be checked and

confirmed as stable in order to proving reliable and long-lived operation. All this is done automatically without need for external intervention.

The turn on cycle is seamless when there is no microprocessor control installed. When the COMMUNICATION CARD (Comms) is installed, the turn on function of the main supply is controlled from a remote terminal. In this condition, only the small SMPS supply in the amplifier is active. The operator is able to turn the amplifier on from the remote terminal. The Comms card then instructs the power supply to commence its turn on cycle.

Should the link between the remote terminal and the amplifier be lost, the Local/Network switch on the front panel allows full control of both turn on and operation of the amplifier's digital functions. When switched to the "local" position the turn on cycle is identical to that of a "basic" amplifier. If the Cobra card is installed, then the VFD display and its four function buttons allow control of the amplifier from the front panel.

Each time AC power is removed from the amplifier chassis, either by turning the power switch off or through an unintentional loss of A/C power, the power supply resets to zero and forces a fresh turn on cycle.

1.10 Timing of Turn-on Sequence:

Switching on the rear panel power switch, activates a Standby Supply in approx. 200 milliseconds.

This standby supply energizes (a), (b) and (c) above.

Depending on the model of amplifier, there are differences between internal components, sequences and operations.

In microprocessor controlled amplifiers, a control signal is fed to the amplifier which, when activated powers-on a high current relay. This allows A/C mains to be applied to the main Switch Mode Power Supply.

In non-microprocessor controlled amplifiers, A/C mains is applied to the main Switch Mode Power Supply automatically within two seconds after the power switch is turned on. A relay is activated powering on the main switch mode supply.

At this point, the Main Bus Capacitors are powered. This voltage is dependent upon the peak value of the incoming A/C mains, which differs around the world. Nominally the range of voltages found is between 100 – 240V and 50/60 Hz. However, often the actual line voltage can vary as much as 20% above and below these nominal levels. In MTS amplifiers a PFC stage is used to control and regulate the supply to maintain stable and consistent performance to specifications regardless of the country with which the product is being operated.

Power Factor Correction: In the next two seconds the PFC control circuits are activated and the bus voltage reaches an operating value of approximately 385 volts. The main Switch Mode circuits operate on this bus power.

About one second later the Surge Control circuit bypasses the Surge-Guard components allowing current to be drawn from the supplies.

When monitoring deems conditions to be stable, and within approximately three seconds, the Class-D Control Bus is activated.

Two to three seconds later, the individual Output Speaker Relays are energized placing the amplifier in operational mode.

The entire sequence from turn-on to amplifier operation is approximately eight to ten seconds.

Front panel Standby (red) and Power (blue) LEDs: On initial power up, both LEDs are illuminated. Indicating that the Power is on and that the amplifier sections are in Standby mode. Once the Class-D control bus is activated the standby LED is turned off.

1.11 Installing Your Amplifier:

What is Included: Each MTSI Amplifier is shipped with the following:

- An A/C power cable, IEC type with appropriate mains plug for the region in which it is sold.
- Phoenix/Euro-type input connectors, as required per channel.
- Degson-type speaker load output connectors, as required per module.
- Basic Owner's/Operator's Manual and other documentation.

For full documentation on amplifier software, control and other protocols, please refer to www.mediatechnologysystems.com website for downloads and additional valuable information. Or contact your official distributor.

Rack Mounting of Equipment: MTSI amplifiers are built to industry standard 19"/48.25cm, rack mount dimensions, and are 2U – 3.5"/8.9cm in front panel height.

Use four screws of appropriate thread pitch and size to your rack. Since the amplifier is designed for low profile to reduce rack space, it is advisable to consider supporting the rear of the amplifier. Most rack systems have available hardware to provide this support where needed. Be sure to support the rear of the amplifier as the front rack-ear screws are fitted.

In fixed installations rear support is recommended. In any portable or mobile system, it is mandatory.

Air Flow and Cooling Requirements: MTSI amplifiers pull cool air in from the right side panel through the electronics and out of the left side (as you look from the front).

Make sure that your rack is supplied with cool air flowing through the rack.

Make sure that nothing can block the airflow in or out of the equipment.

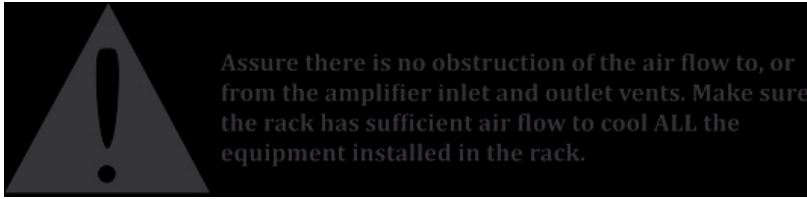

A/C Mains Power Connection: MTSI amplifiers are designed to operate on all standard A/C Power voltage and frequencies found Worldwide. There is no requirement to set selectors etc.

IEC Socket: The IEC socket is designed so the connector can only fit in one way. Make sure to align properly and that the connector is seated fully into the socket. Do not force the connector.

Power Cable: Use the power cable supplied with the amplifier or an equivalently rated replacement. Make sure the line cable is of at least #14 AWG (American Wire Gauge). Use of cable with thinner conductors can cause overheating of the cable and risk of fire and safety.

Incoming Power Requirements: Make sure that the power circuit, cables, sockets, breakers etc., feeding your amplifier are rated to support the power indicated on the rear panel of your amplifier (in Watts). Care should be taken to assure that the power distribution arrangements are sufficient for the nominal A/C Voltage and the resultant current being sourced by your amplifier.

1.12 Setup

Unpacking your amplifier: It is recommended that the carton and packing material is retained so the amplifier may be shipped for service should this be required. Any damage caused by improper packaging will not be covered under warranty. Should you choose to dispose of the carton and packaging, make sure to dispose of these parts according to local, state and national requirements and good ecological practice.

What comes with your amplifier: A full set of input and output “line” connectors are fitted as standard to your new MTSI multi-channel amplifier. An IEC power cable is supplied that is appropriate to the territory within which the amplifier is supplied. Should you choose to change this cable, make sure the replacement is of appropriate power capacity and that it has all three conductors properly connected.

Installing your amplifier: When installing your amplifier to appropriately designed and installed rack rails, make sure to mount using four screws. These screws should be of a size and strength to support the amplifier. Although MTSI amplifiers are intended for fixed installation, should you consider rack mounted amplifiers in mobile applications, make sure to support the rear of the amplifier.

Ensure proper cooling: MTSI amplifiers are Class-D/SMPS/PFC designs. As such they are highly efficient, generating considerably higher output levels for given input power. In conventional amplifiers, often, over 50% of the power input to the amplifier is dissipated as heat. Heat is the enemy of electronics as well as being wasteful. Even though the MTSI amplifiers are efficient, there is heat generated internally that must be dissipated and vented. A fan is installed that draws air from the left side of the amplifier, throughout the components and sub assemblies, and out of the right side of the product. Make sure that there is good airflow in the installation rack.

Level Controls (where fitted): On models where there are rear panel input level trim controls, set these to the full counter-clockwise position, or minimum. This is an advisable set up convention which avoids accidental high level signals potentially damaging the loudspeaker. As required, and with an appropriate signal, you can gradually bring up the signal level through the amplifier and confirm proper system operation.

High Pass Filters: (where fitted): The Hi-Pass, or Lo-Cut filters on MTSI amplifiers are designed to smoothly reduce or limit the amount of low frequency energy in a signal. In Paging – Voice systems where communication is the primary function, excessive low frequency energy is detrimental since it reduces available headroom in the system by amplifying signals that often are not audible. Secondly, loudspeakers are protected against damage through excessive low frequency energy from dropped mics, switching noise, ‘Breath POP’s” etc.

Comms Module DIP Switches: (where fitted)...

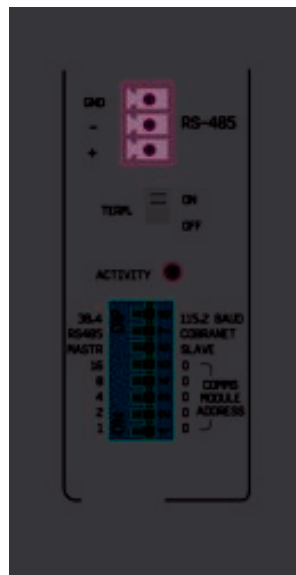

RS485 ground and termination selector: (where fitted) See relevant section.

Local/Network Switch: (Front Panel, where fitted): See relevant section.

70/100 Volt Power Supply Selection/Set-up: To operate in either 70V or 100V mode, the amplifier must be ‘booted up’ with the ‘Output Mode’ selector switch in the desired setting. **After any action to change this switch, the amplifier must be re-started.**

The internal sensing and changes to gain structure and control & monitoring rely on the amplifier booting with the switch in the intended operating position. Do not change this setting whilst the amp is powered up!



1.13 Input Wire and Connectors:

Each channel input uses a Euro/Phoenix type input connector set. The line connectors are supplied with your amplifier. It is recommended that balanced connections are used for all inputs in professional applications, since significantly less hum, buzz or other noise are induced on the signal, particularly in long cable runs such as are found in installations.

Cable/Line Connections: For balanced input connect as below. For unbalanced input, connect the unused, minus terminal of the connector to the shield as shown.

Input Block Balanced

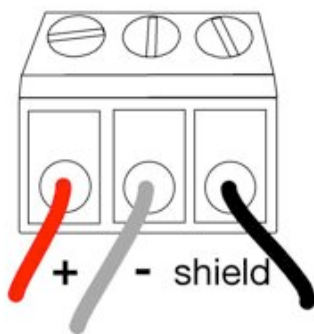

Input Block Unbalanced

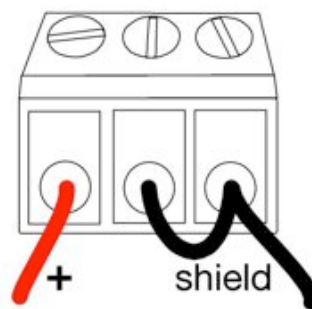

Note: The 'Line Input' Phoenix/Euro type connectors on the left side of the I/O area show the Channel Number, the plus, minus and GND or shield. In the interests of reducing ground anomalies in large systems where signals may be routed from remote sources with the opportunity for ground anomalies, it is common practice to 'lift' the shield on a signal cable, at the source, or send and connect it at the receiving end. Under any and all circumstances, for safety, check and make sure that proper A/C and systems grounding is practiced. Your MTSI amplifier is designed in keeping with correct safety grounding approved under international accepted standards. It is also designed with an understanding of the 'Real-World' circumstances of systems installation. The instrumentation differential input, the signal grounding practice and other build aspects are designed to provide the minimum opportunity for A/C and signal borne noise and interference to contaminate your program material and system functionality.



1.14 Output Wire and Connectors:



AMPLIFIER OUTPUT SAFETY WARNING:
Do not touch output terminals while the amplifier is powered on. It is good practice to only make connections or changes whilst an amplifier, or equipment is off. Amplifier outputs can output hazardous energy!



When choosing and installing speaker cable, always use the heaviest wire gauge possible. Undersized speaker cable can have a significant amount of "R" which, by raising the impedance, will reduce usable power delivered the speaker(s), where it is desired. Power dissipated in the cables is wasted as heat!

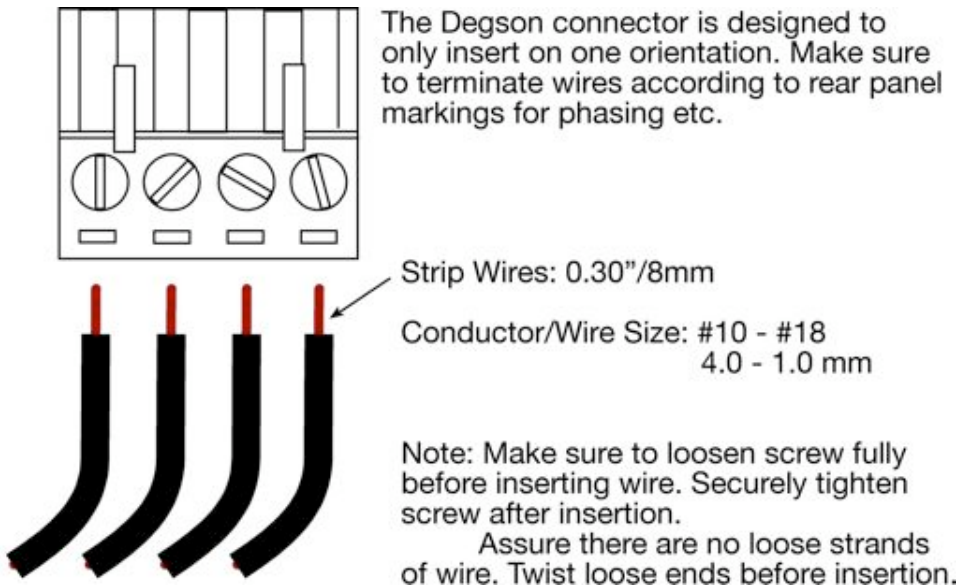

The following graphic is extracted from the COM-Series amplifier rear panel, and shows the output connectors for main speaker and standby amplifier input.

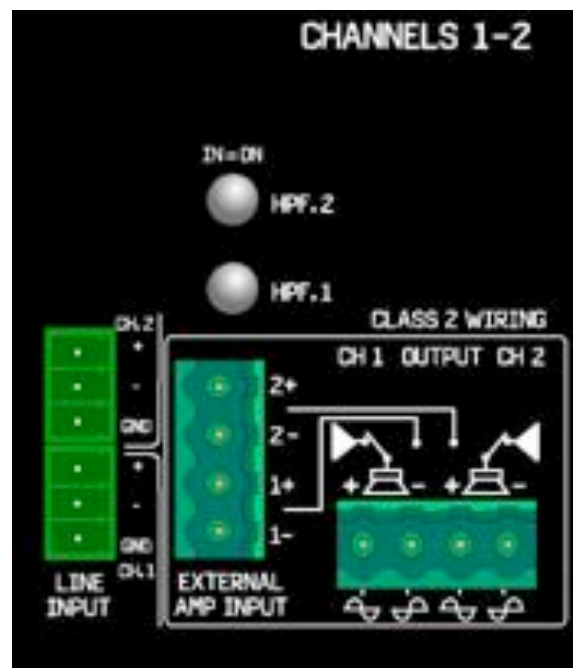

Note: Phase and other nomenclature for inputs and outputs.

1.15 A/C Mains power requirements:

MTSI amplifiers use PFC/SMPS supplies which do not require any change of settings for normal operation on all internationally found standard voltages, and frequencies. Further, the SMPS assures full specified output on voltages from 85V A/C to 250 V A/C. Thus on the often found sagged or browned out power supply, the MTS amplifier will deliver full rated power and headroom. (see notes). This ability notwithstanding, care should be taken in designing the power distribution to the amplifier(s) and equipment that is capable of supporting the sustained power required for proper operation.

Insufficient cable capacity can cause heat to build up in the power supply cables to the amp racks, causing a voltage drop. The ability of the MTS amplifiers to deliver full specified power on any voltage even if it has sagged can exacerbate problems with a poorly specified and installed A/C power delivery system.

Each MTSI amplifier is marked on the rear panel with the nominal power requirements, in Watts. Connect the appropriate A/C power line cord to the IED socket. Note the pins are oriented to allow connection in only the correct orientation. Do not lift the ground connection.

2 Control and Monitoring

There are two variants of the MTS Multichannel amplifier series that provide control and monitoring capability. The simplest are the –S models, which add an RS485 port to the standard AV series (LoZ 4/8ohm output impedance) and PAG series (HiZ 70/100volt output drive) amplifiers. This chapter covers the –S versions, eg AV758-S and PAG3006-S.

The second variant are the SI and COM series Network amplifiers and will be covered in the next chapter.

The –S models utilize an 8 bit microprocessor with 10 A-D measurement ports. There is one microprocessor for each pair of amplifier channels and another microprocessor to handle both RS485 communications & the SMPS control and monitoring.

2.1 Amplifier Parameters

There are potentially up to 8 amplifier modules in each amplifier chassis, where each amplifier module has the following parameters

Parameter in each 2 channel amplifier module	Size	External Read/Write Status
Signal Level 1 Pre	8 bit	R
Signal Level 2 Pre	8 bit	R
Signal Level 1 Post	8 bit	R
Signal Level 2 Post	8 bit	R
Output Current 1	10 bit	R
Output Current 2	10 bit	R
Output Voltage 1	10 bit	R
Output Voltage 2	10 bit	R
Temperature	8 bit	R
Attenuation 1	8 bit	R/W
Attenuation 2	8 bit	R/W
Mute 1	1 bit	R/W
Mute 2	1 bit	R/W
DC Fault 1	1 bit	R
DC Fault 2	1 bit	R
Short Cct Fault 1	1 bit	R
Short Cct Fault 2	1 bit	R
HPF 1	1 bit	R
HPF 2	1 bit	R
Clip 1	1 bit	R
Clip 2	1 bit	R
Bridge Mode	1 bit	R

Table 2.1: Amplifier module parameters

Where...

- R = read only
- R/W = read and write
- Pre = Analog input signal, pre-attenuator
- Post = Analog input signal, post-attenuator
- Bridge mode is ONLY applicable to the low impedance models and has 2 settings- bridge or low impedance, the 70volt and 100volt models are already bridged output on all channels.

In addition to the amplifier modules, there is a host processor monitoring the communications and main power supply. The host processor has the following parameters

Parameter in SMPS module	Size	External Read/Write Status
Supply +15v	8 bit	R
Supply +5v	8 bit	R
Main Amp +Vcc	8 bit	R
Amplifier model	8 bit	R
PFC Thermal	8 bit	R
SMPS Thermal	8 bit	R
Standby	1 bit	R/W
Local/Network	1 bit	R
Modules Present	8bit	R
Over Current Fault	1 bit	R
Over Voltage Fault	1 bit	R

Table 2.2: Amplifier host processor parameters

The full data format of each amplifier module (Table 2.3) and main amplifier host processor (Table 2.4) are given below.

2.1.1 Data format for each amplifier module host processor (module 1, channels 1&2 shown).

Note: Bit stuffing is involved for the output voltage and current, where the high bits (bits 9 & 10) of each sequence of 4 bytes are stuffed into the 5th byte. For example, bits 9 & 10 for OCUR1 are bits 1 & 2 of the 5th byte, bits 9 & 10 for OCUR2 are bits 3 & 4, of the 5th byte and so on. The color coding used for the first byte (in Table 2.3 above) will match the location of the high bits to the lower byte.

Name	Bit 8	Bit 7	Bit 6	Bit 5	Bit 4	Bit 3	Bit 2	Bit 1
SIG1PE	Bit8	Bit7	Bit6	Bit5	Bit4	Bit3	Bit2	Bit1
SIG1PO	Bit8	Bit7	Bit6	Bit5	Bit4	Bit3	Bit2	Bit1
SIG2PE	Bit8	Bit7	Bit6	Bit5	Bit4	Bit3	Bit2	Bit1
SIG2PO	Bit8	Bit7	Bit6	Bit5	Bit4	Bit3	Bit2	Bit1
OCUR1	Bit8	Bit7	Bit6	Bit5	Bit4	Bit3	Bit2	Bit1
OCUR2	Bit8	Bit7	Bit6	Bit5	Bit4	Bit3	Bit2	Bit1
OVOL1	Bit8	Bit7	Bit6	Bit5	Bit4	Bit3	Bit2	Bit1
OVOL2	Bit8	Bit7	Bit6	Bit5	Bit4	Bit3	Bit2	Bit1
HIGH BITS	Bit10	Bit9	Bit10	Bit9	Bit10	Bit9	Bit10	Bit9
TEMP1	Bit8	Bit7	Bit6	Bit5	Bit4	Bit3	Bit2	Bit1
ATT1	Bit8	Bit7	Bit6	Bit5	Bit4	Bit3	Bit2	Bit1
ATT2	Bit8	Bit7	Bit6	Bit5	Bit4	Bit3	Bit2	Bit1
FAULT1	0	0	Clip2	Clip1	SC2	SC1	DC2	DC1
STATUS1	X	X	X	X	0	Bridge	HPF2	HPF1
CONTROL1	X	X	X	X	0	0	Mute2	Mute1

Table 2.3: Amplifier Module processor dataset

Where...

SIG1PE = Signal, channel 1, pre attenuator

SIG2PO = Signal, channel 2, post attenuator

OCUR1 = Output current, channel 1

OVOL2 = Output voltage, channel 2

TEMP1 = Temperature, Module 1

ATT1 = Attenuation setting, channel 1

FAULT1 = Clip, Short Circuit and DC protect status of module 1 (ie channels 1 & 2)

STATUS1 = Status of module 1, ie bridge settings and high pass filter settings

CONTROL1 = Output relay settings for module 1 (ie channels 1 & 2)

X = Not valid, as only bottom ASCII byte is transmitted

2.1.2 Data format for RS485 port and SMPS host processor

Name	Bit 8	Bit 7	Bit 6	Bit 5	Bit 4	Bit 3	Bit 2	Bit 1
VCC5	Bit8	Bit7	Bit6	Bit5	Bit4	Bit3	Bit2	Bit1
VCC15	Bit8	Bit7	Bit6	Bit5	Bit4	Bit3	Bit2	Bit1
VCCAMP	Bit8	Bit7	Bit6	Bit5	Bit4	Bit3	Bit2	Bit1
MODEL	100v	70v	0	1200W	600W	300W	150W	75W
PFCTM	0	0	0	0	0	0	0	0
SMPSTM	Bit8	Bit7	Bit6	Bit5	Bit4	Bit3	Bit2	Bit1
FAULTM	X	X	X	X	0	LOCAL	OVRVOL	OVRCUR
CONTROLM	X	X	X	X	0	0	0	Standby
STATUSM	Module8	Module7	Module6	Module5	Module4	Module3	Module2	Module1

Table 2.4: SMPS processor dataset

Where...

VCC5 = +5volt rail

VCC15 = +15volt rail

VCCAMP = Main amplifier power rail

PFCTM = PFC module temperature. Future provision, so all bits set to zero.

SMPSTM = SMPS module temperature

FAULTM = Front panel Local/Network setting and over current and over voltage fault status for power supply

CONTROLM = Standby operation. There are 2 power supplies in the amplifier, a small low voltage SMPS that drives the +5volt supply and a large SMPS that drives the +/-15volt and +/-VCC rails. The ControlM bit will allow the main SMPS to be switched on/off, leaving only the small 5volt rail in operation (ie Standby mode). Note: To switch off the amplifier completely, the main power switch on the rear of the amplifier must be toggled.

STATUSM = Presence of up to 8 dual channel amplifier modules.

MODEL = whether the amplifier is 75watts, 150watts....1200watts and if the output is low impedance, 70volt or 100volt

X = Not valid, as only bottom ASCII byte is transmitted

Note: There will always be an amplifier processor present, so table 15 will always be applicable. However, there will be between 1 and 8 amplifier modules present, so Table 2.3 will apply to EACH amplifier module.

As the data is transmitted in ASCII format, there will be two bytes of ASCII for each byte of HEX data. The actual transmitted datasets are given in tables 2.5 and 2.6 below.

2.1.3 Data format for amplifier module host processor

Name	ASCII
SIG1PEL	Byte 1
SIG1PEH	Byte 2
SIG1POL	Byte 1
SIG1POH	Byte 2
SIG2PEL	Byte 1
SIG2PEH	Byte 2
SIG2POL	Byte 1
SIG2POH	Byte 2
OCUR1L	Byte 1
OCUR1H	Byte 2
OCUR2L	Byte 1
OCUR2H	Byte 2
OVOL1L	Byte 1
OVOL1H	Byte 2
OVOL2L	Byte 1

Name	ASCII
SIG15PEL	Byte 1
SIG15PEH	Byte 2
SIG15POL	Byte 1
SIG15POH	Byte 2
SIG16PEL	Byte 1
SIG16PEH	Byte 2
SIG16POL	Byte 1
SIG16POH	Byte 2
OCUR15L	Byte 1
OCUR15H	Byte 2
OCUR16L	Byte 1
OCUR16H	Byte 2
OVOL15L	Byte 1
OVOL15H	Byte 2
OVOL16L	Byte 1

OVOL2H	Byte 2	...	OVOL16H	Byte 2
HIGH BITSL	Byte 1		HIGH BITSL	Byte 1
HIGH BITSH	Byte 2		HIGH BITSH	Byte 2
TEMP1L	Byte 1		TEMP8L	Byte 1
TEMP1H	Byte 2		TEMP8H	Byte 2
ATT1L	Byte 1		ATT15L	Byte 1
ATT1H	Byte 2		ATT15H	Byte 2
ATT2L	Byte 1		ATT16L	Byte 1
ATT2H	Byte 2		ATT16H	Byte 2
FAULT1L	Byte 1		FAULT8L	Byte 1
FAULT1H	Byte 2		FAULT8H	Byte 2
STATUS1	Byte 1		STATUS8	Byte 1
CONTROL1	Byte 1		CONTROL8	Byte 1

Table 2.5: ASCII data transmission format for amplifier module dataset

Where: Byte 1 & Byte 2 = 0x30 (ASCII "0") ~ 0x39 (ASCII 0x39) and 0x41 (ASCII "A") ~ 0x46 (ASCII "F"). In the case of the single ASCII byte Status signals, the upper 4 bits are discarded.

2.1.4 Data format for comms module host processor

Name	ASCII
VCC5L	Byte 1
VCC5H	Byte 2
VCC15L	Byte 1
VCC15H	Byte 2
VCCAMPL	Byte 1
VCCAMPH	Byte 2
MODEL	Byte 1
MODEL	Byte 2
PFCTML	Byte 1
PFCTMH	Byte 2
SMPSTML	Byte 1
SMPSTMH	Byte 2
FAULTM	Byte 1
CONTROLM	Byte 1
STATUSM	Byte 1
STATUSM	Byte 2

Table 2.6: ASCII data transmission format for comms module dataset

Where: Byte 1 & Byte 2 = 0x30 (ASCII "0") ~ 0x39 (ASCII "9") and 0x41 (ASCII "A") ~ 0x46 (ASCII "F"). In the case of the single ASCII byte Status signals, the upper 4 bits are discarded.

2.2 Local/Network Switch

When the switch is set to "Local", the amplifier ignores write instructions from the RS485/Cobranet control ports. However, read instructions are still processed. When the switch is set to "Network, the amplifier will respond to both read and write instructions from the RS485/Cobranet port.

Bit3 in the V-BUS FaultM register, ie "Local" will be set to 1 when the switch is set to local and to 0 when the switch is set to Network. This will enable the operator to remotely monitor the Local/Network switch, incase of accidently operation and unexpected loss of control.

The front panel Local/Network switch will have 4 modes of operation.

- On power up and the switch is in Local. Control of the amplifier is disabled, but monitoring is enabled. Standby control is not possible.
- On power up and the switch is in Network: Both SMPS supplies will come on, but a remote processor can now take control of the amplifier and (if required) switch the main SMPS into and out of Standby.
- At any time after power up the switch is changed from Network to Local, then control will be disabled. Note, if the amplifier is in Standby, then changing the switch position to Local will force the main SMPS on and the main VCC rails will go live.
- At any time after power up the switch is changed from Local to Network, then control will be enabled.

2.3 Metrics

2.3.1 Pre & Post attenuator signals

Both Pre and Post attenuator signals will be represented by an 8 bit hexadecimal value, transmitted as 2 ASCII characters, where 1 step in the 8bit value represents 0.25dBu and the full range is -40dBu...+23.75dBu. The actual range for each signal will be limited to a more practical meter range of 48dB, as follows

- Pre attenuator signal
 - 0x40 = -24dBu.
 - Every 0x01 step = 0.25dBu
 - 0xA0 = 0dBu
 - 0xFF = +23.75dBu-nominal max
- Post attenuator signal
 - 0x00 = -40dBu
 - Every 0x01 step = 0.25dBu

- 0xA0 = 0dBu
- 0xBF = +7.75dBu-nominal max

The Host PC would need to multiply the 8 bit reading by 0.25dBu and subtract either 24dBu or 40dBu for the Pre and Post signals respectively, to obtain the correct value.

2.3.2 Output Current & Voltage signals

The output current and voltage signals are transmitted as a 10bit signal with 3 ASCII characters representing the three hex digits. The signal will vary from 0x000 to 0x3FF, where one bit is represented as follows...

- 75watt low impedance (voltage) = 34.7 millivolts/bit
- 75watt low impedance (current) = 13.58 milliamps/bit
- 75watt 70volt (voltage) = 125.8 millivolts/bit
- 75watt 70volt (current) = 3.46 milliamps/bit
- 75watt 100volt (voltage) = 174.6 millivolts/bit
- 75watt 100volt (current) = 2.45 milliamps/bit
- 150watt low impedance (voltage) = 45.6 millivolts/bit
- 150watt low impedance (current) = 19.18 milliamps/bit
- 150watt 70volt (voltage) = 125.8 millivolts/bit
- 150watt 70volt (current) = 6.93 milliamps/bit
- 150watt 100volt (voltage) = 174.6 millivolts/bit
- 150watt 100volt (current) = 4.9 milliamps/bit
- 300watt low impedance (voltage) = 62.9 millivolts/bit
- 300watt low impedance (current) = 27.72 milliamps/bit
- 300watt 70volt (voltage) = 125.8 millivolts/bit
- 300watt 70volt (current) = 13.86 milliamps/bit
- 300watt 100volt (voltage) = 174.6 millivolts/bit
- 300watt 100volt (current) = 9.8 milliamps/bit
- 600watt low impedance (voltage) = 125.8 millivolts/bit
- 600watt low impedance (current) = 27.72 milliamps/bit
- 600watt 70volt (voltage) = 125.8 millivolts/bit (Note low impedance and 70volt are the same)
- 600watt 70volt (current) = 27.72 milliamps/bit (Note low impedance and 70volt are the same)
- 600watt 100volt (voltage) = 174.6 millivolts/bit
- 600watt 100volt (current) = 19.6 milliamps/bit
- 1200watt low impedance (voltage) = 125.8 millivolts/bit
- 1200watt low impedance (current) = 55.43 milliamps/bit
- 1200watt 70volt (voltage) = 125.8 millivolts/bit (Note low impedance and 70volt are the same)
- 1200watt 70volt (current) = 55.43 milliamps/bit (Note low impedance and 70volt are the same)
- 1200watt 100volt (voltage) = 174.6 millivolts/bit
- 1200watt 100volt (current) = 39.19 milliamps/bit

The host processor would need to multiply the 10 bit reading by the scaling factor above to obtain the correct value.

2.3.3 Temperature

The temperature signals are transmitted as an 8bit hexadecimal format signal with 2 ASCII characters representing the hexadecimal digits. The temperature range is 98degC, where -10degC = "00" (ASCII 0x30, 0x30)... 88degC = "62" (ASCII 0x36, 0x32). The host PC would need to convert hex to decimal and subtract decimal "10" from the value transmitted to get degC

2.3.4 Voltage rails

The voltage rails will all be transmitted as a 8 bit signals. The signal will vary from 0x00 to 0xFF, where one bit is represented as follows...

- +5volts = 7mV per step: Multiply the 8 bit result by 7mV (to get the voltage offset) and then add 4 volts to get the actual rail voltage
- +15volts = 21mV per step: Multiply the 8 bit result by 21mV (to get the voltage offset) and then add 12 volts to get the actual rail voltage
- 75w Vcc= +/-29v, ie 40.5mV per step: Multiply the 8 bit result by 40.5mV (to get the voltage offset) and then add 23 volts to get the actual rail voltage
- 150w Vcc= +/-39v, ie 54.4mV per step: Multiply the 8 bit result by 54.4mV (to get the voltage offset) and then add 30 volts to get the actual rail voltage
- 300w Vcc= +/-55v, ie 76.8mV per step: Multiply the 8 bit result by 76.8mV (to get the voltage offset) and then add 42 volts to get the actual rail voltage
- 600w, 1200w low impedance and all 70volt models Vcc= +/-110v, ie 153.6mV per step: Multiply the 8 bit result by 153.6mV (to get the voltage offset) and then add 84 volts to get the actual rail voltage
- 100volt Vcc= +/-154v, ie 215mV per step: Multiply the 8 bit result by 215mV (to get the voltage offset) and then add 116 volts to get the actual rail voltage

Note: All the values are peak signals, voltages and currents

2.3.5 Attenuator settings

The attenuators range from +12dB to -51.75dB in 256 steps of 0.25dB per step. The settings are...

0xFF = 255 = +12dB

0xCF = 207 = 0dB

0x00 = -51.75dB

Multiply the attenuation setting bit by 0.25 and subtract 51.75, to get the attenuation in dB, eg...

$255 \times 0.25 - 51.75 = +12\text{dB}$

$0 \times 0.25 - 51.75 = -51.75\text{dB}$

The amplifier firmware will remember the last gain setting before power down and will power up with the same gain setting.

2.4 V-BUS: RS485 control port protocol

The V-BUS protocol specification covers communication between one or more MTS –S Series amplifiers and a host processor or peripheral control panel. In the case of a Host processor, the MTS amplifier operates in slave mode and only responds to polling from the host.

The host can be a simple PC with a custom application or a 3rd party AV control system product (eg AMX or Crestron).

When switched to Master mode, the MTS –S series amplifiers poll the attached MTS wall controls (TBA). The wall controls are simple volume panels or source selectors. At present, Master mode is disabled.

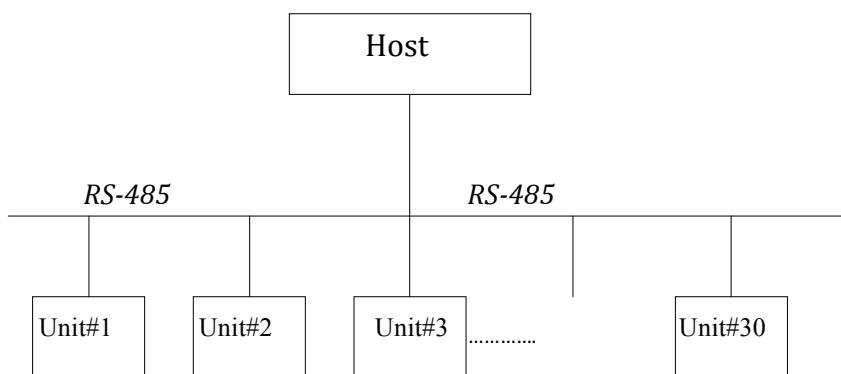

Figure 2.1 Network Configuration of V-Bus Communication

2.4.1 Attenuator settings

Hardware interface of RS-485 line is shown in Table 2.7.

No.	Item	Description
1	Communication system	Two-wire, half-duplex
2	Synchro system	Asynchronous (out of synchronization)
3	Line control system	Polling / selecting
4	Data bit	8 bits
5	Parity	None
6	Stop Bit	1 stop bit
7	Error control system	BCC (checksum)
8	Bit transmission order	LSB first
9	Baud rate	38.4 or 115.2 [kbps] (set using DIP switches)
10	Text length	Max. 524 [bytes]

Table 2.7 Hardware Interface of RS-485 Port

2.4.2 ASCII Codes

ASCII codes used in V-BUS communication are listed in Table 2.8

	00	10	20	30	40	50	60	70
00			SPC	0		P		p
01				1	A	Q	a	q
02	STX			2	B	R	b	r
03	ETX			3	C	S	c	s
04				4	D	T	d	t
05		NAK		5	E	U	e	u
06	ACK			6	F	V	f	v
07				7	G	W	g	w
08				8	H	X	h	x
09				9	I	Y	i	y
0A					J	Z	j	z
0B					K			k
0C					L			l
0D					M		m	
0E					N		n	
0F					O		o	

Table 2.8 ASCII character set

Due to addressing limits for the single character UA (unit address-see section 2.4), the extended ASCII character set used the Microsoft Windows will be used to extend the formal 7bit ASCII character set to 8 bits and 255 addresses-see Table 2.9 below

ASCII Character Codes Chart 2

Dec	Hex	Char	Dec	Hex	Char	Dec	Hex	Char	Dec	Hex	Char
128	80	Ç	160	A0	à	192	C0	Ł	224	E0	α
129	81	È	161	A1	á	193	C1	ł	225	E1	Β
130	82	É	162	A2	â	194	C2	Ł̄	226	E2	β
131	83	Ê	163	A3	ã	195	C3	ł̄	227	E3	Γ
132	84	Ë	164	A4	ä	196	C4	—	228	E4	γ
133	85	Ě	165	A5	å	197	C5	+	229	E5	δ
134	86	Ï	166	A6	æ	198	C6	†	230	E6	Ε
135	87	Ĭ	167	A7	ç	199	C7	‡	231	E7	ε
136	88	Ī	168	A8	ċ	200	C8	£	232	E8	Ϝ
137	89	Ĵ	169	A9	ċ̇	201	C9	ƒ	233	E9	ϝ
138	8A	Ķ	170	AA	ċ̈	202	CA	Δ	234	EA	Ϝ̄
139	8B	Ĵ̇	171	AB	ċ̈̇	203	CB	ƒ̇	235	EB	ϝ̄
140	8C	Ĵ̈	172	AC	ċ̈̈	204	CC	ƒ̈	236	EC	Ϝ̈
141	8D	Ĵ̈̇	173	AD	ċ̈̇̇	205	CD	ƒ̇̇	237	ED	ϝ̈̇
142	8E	Ĵ̈̈	174	AE	ċ̈̈̇	206	CE	ƒ̈̇	238	EE	Ϝ̈̇̇
143	8F	Ĵ̈̈̇	175	AF	ċ̈̈̇̇	207	CF	ƒ̈̇̇	239	EF	ϝ̈̈̇
144	90	Ĵ̈̈̈	176	B0	ċ̈̈̈̇	208	D0	Δ̇	240	F0	Ϝ̈̈̇̇
145	91	Ĵ̈̈̈̇	177	B1	ċ̈̈̈̇̇	209	D1	ƒ̇̇̇	241	F1	ϝ̈̈̇̇̇
146	92	Ĵ̈̈̈̈	178	B2	ċ̈̈̈̈̇	210	D2	ƒ̈̇̇̇	242	F2	Ϝ̈̈̈̇̇
147	93	Ĵ̈̈̈̈̇	179	B3	ċ̈̈̈̈̇̇	211	D3	ƒ̇̇̇̇	243	F3	ϝ̈̈̈̇̇̇
148	94	Ĵ̈̈̈̈̈	180	B4	ċ̈̈̈̈̈̇	212	D4	ƒ̈̇̇̇̇	244	F4	Ϝ̈̈̈̈̇̇
149	95	Ĵ̈̈̈̈̈̇	181	B5	ċ̈̈̈̈̈̇̇	213	D5	ƒ̇̇̇̇̇	245	F5	ϝ̈̈̈̈̇̇̇
150	96	Ĵ̈̈̈̈̈̈	182	B6	ċ̈̈̈̈̈̈̇	214	D6	ƒ̈̇̇̇̇̇	246	F6	Ϝ̈̈̈̈̈̇̇
151	97	Ĵ̈̈̈̈̈̈̇	183	B7	ċ̈̈̈̈̈̈̇̇	215	D7	ƒ̇̇̇̇̇̇	247	F7	ϝ̈̈̈̈̈̇̇̇
152	98	Ĵ̈̈̈̈̈̈̈	184	B8	ċ̈̈̈̈̈̈̈̇	216	D8	ƒ̈̇̇̇̇̇̇	248	F8	Ϝ̈̈̈̈̈̈̇̇
153	99	Ĵ̈̈̈̈̈̈̈̇	185	B9	ċ̈̈̈̈̈̈̈̇̇	217	D9	ƒ̇̇̇̇̇̇̇	249	F9	ϝ̈̈̈̈̈̈̇̇̇
154	9A	Ĵ̈̈̈̈̈̈̈̈	186	BA	ċ̈̈̈̈̈̈̈̈̇	218	DA	ƒ̈̇̇̇̇̇̇̇	250	FA	Ϝ̈̈̈̈̈̈̈̇̇
155	9B	Ĵ̈̈̈̈̈̈̈̈̇	187	BB	ċ̈̈̈̈̈̈̈̈̇̇	219	DB	ƒ̇̇̇̇̇̇̇̇	251	FB	ϝ̈̈̈̈̈̈̈̇̇̇
156	9C	Ĵ̈̈̈̈̈̈̈̈̈	188	BC	ċ̈̈̈̈̈̈̈̈̈̇	220	DC	ƒ̈̇̇̇̇̇̇̇̇	252	FC	Ϝ̈̈̈̈̈̈̈̈̇̇
157	9D	Ĵ̈̈̈̈̈̈̈̈̈̇	189	BD	ċ̈̈̈̈̈̈̈̈̈̇̇	221	DD	ƒ̇̇̇̇̇̇̇̇̇	253	FD	ϝ̈̈̈̈̈̈̈̈̇̇̇
158	9E	Ĵ̈̈̈̈̈̈̈̈̈̈	190	BE	ċ̈̈̈̈̈̈̈̈̈̈̇	222	DE	ƒ̈̇̇̇̇̇̇̇̇̇	254	FE	Ϝ̈̈̈̈̈̈̈̈̈̇̇
159	9F	Ĵ̈̈̈̈̈̈̈̈̈̈̇	191	BF	ċ̈̈̈̈̈̈̈̈̈̈̇̇	223	DF	ƒ̇̇̇̇̇̇̇̇̇̇	255	FF	ϝ̈̈̈̈̈̈̈̈̈̇̇̇

Table 2.9: Extended ASCII character set

2.5 Communication Protocol

The dataset for the V-BUS communications uses HEX for the housekeeping data (STX, ETX, UA, SA, BCC, SEL, DAT) and ASCII for the user data communication (CMD, SIZE, DATA) between host and each unit. ASCII implies that each hex byte is converted to a 2-byte ASCII code. V-BUS communication is defined in detail below.

2.5.1 Amplifier address

Table 2.10 shows the relevant addresses. The emboldened rows are relevant to V-BUS. The other addresses are for G-Bus compatibility. The maximum number of units to be connected to V-BUS is 32.

Addresses are configured using the DIP switches on the back of the unit.

No.	Equipment	Address	Max. number
1	Reserved	0x00~0x1F	32
2	Reserved	0x20~0x3F	32
3	Host	0x41	1
4	Reserved	0x42~0x4B	10
5	Reserved	0x4C~0x4F	4
6	Reserved	0x50~0x5F	16
7	Amplifiers	0x60~0x7F	32
8	Wall Panels	0x80~0xFF	128

Table 2.10 Peripheral equipments and address assign

2.5.2 Transmission control code

Table 2.11 shows transmission control codes used for V-BUS communication protocol.

No.	Control code	ASCII code	Function
1	STX	0x02	Beginning of transmission packet (message)
2	ETX	0x03	End of transmission packet (message)
3	ACK	0x06	Acknowledge
4	NAK	0x15	Negative acknowledge
5	POL	0x50	Polling sequence ("P" of ASCII code)
6	SEL	0x53	Selecting sequence ("S" of ASCII code)
7	DAT	0x44	Unit data ("D" of ASCII code)

Table 2.11 Transmission control codes

2.5.3 Time Limitation

Communications timing limitations for the host processor are listed in Table 2.12. See section 2.6 for details of the communication sequence regarding time limitations.

In V-BUS operation, the time from POL transmission to Global Read data reception from the RS485 port for 4 Amp modules is 12mS. (130 bytes = 1300 transmission bits @ 115200 bps = 8.9mS plus POL command and processing time). It would be recommended not to update faster than 20mS at 115.2kbits/sec. Similarly, 60mS at 38.4kbits/sec.

No.	Description	Time [ms]
1	Permissible waiting time after POL / NAK transmission	40
2	Permissible waiting time after SEL transmission	40
3	Delay time until retransmission in case of NAK reception after SEL transmission	120
4	Minimum time of POL cycle across units	5
5	Response waiting time of POL transmission to the unit caused transmission failure	10

Table 2.12 Time limitations

2.5.4 Number of retransmissions

Table 2.13 shows the number of retransmissions permissible by the Host processor. POL, SEL and DAT are the names of transmission block dataset elements. See section 2.6 Polling Sequence and 2.6 Selecting Sequence for details of the communication sequence regarding retransmission issues.

No.	Description	Number
1	POL transmission (nonresponding after POL or NAK transmission)	2
2	SEL transmission (nonresponding after SEL transmission or receiving NAK)	2
3	DAT transmission (BCC failure of receiving data after POL transmission)	2
4	POL transmission (nonresponding after POL transmission to the unit caused transmission failure)	0

Table 2.13 Number of retransmissions permissible

2.5.5 Transmission Block

Transmission data set blocks used in V-BUS communication are listed in Table 2.14.

No.	Packet Name	Description
1	POL	Polling (Query from Processor to unit)
2	SEL	Selecting (Data transmission from Processor to unit)
3	DAT	Data (Data transmission from unit to Processor)
4	ACK	Acknowledge
5	NAK	Negative acknowledge

Table 2.14 Transmission blocks

2.5.6 Common Format

All transmission blocks begin with "STX" and end with "ETX" as a common format. Note these are entered as HEX and not ASCII format. Destination and Source addresses are specified in the second and the third byte respectively. The fourth byte should be POL, SEL, DAT, ACK or NAK, which will indicate the type of transmission block. SA (Station Address) and UA in Figure 2.2 show Host address and unit address respectively.

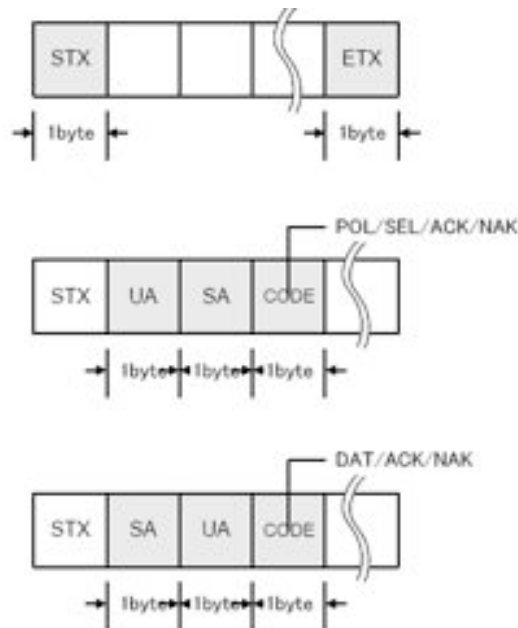

Figure 2.2 Common format of transmission packet

Details of each transmission block in the diagram above are described below.

2.5.7 Polling Block

Polling block is a block transmitted from Host to Unit when starting the polling sequence. Content of the polling block is shown in Figure 2.3.

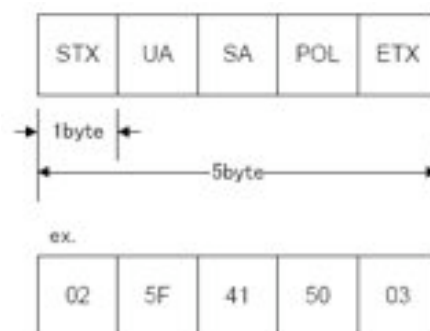

Figure 2.3 Transmission block of polling sequence

2.5.8 Selecting Block

The Selecting block is transmitted from the Host to the Unit when starting a selecting sequence. Contents of the selecting block is shown in Figure 2.4.

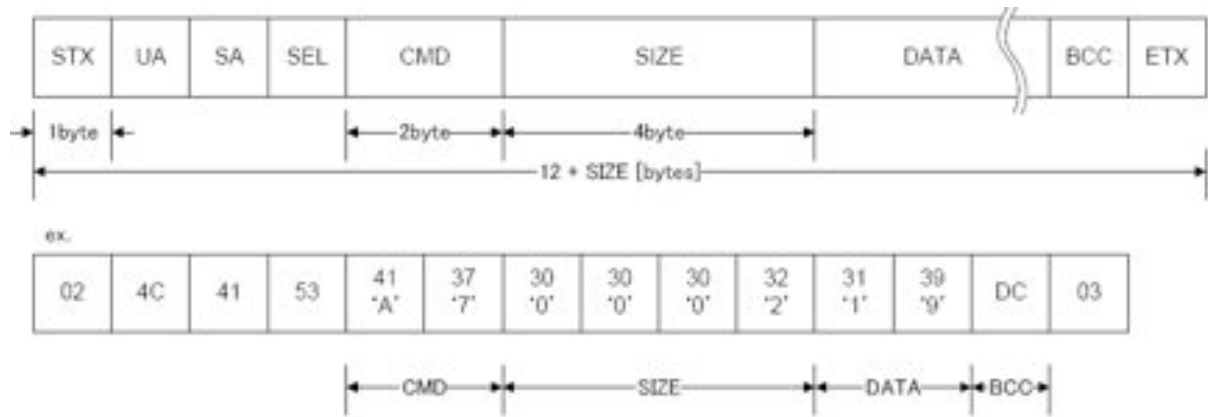

Figure 2.4 Transmission block of selecting sequence

CMD specifies the command number defined for each unit. SIZE specifies byte size of the DATA section. DATA specifies data defined for each CMD. BCC specifies check sum of CMD, SIZE and DATA parts. See 2.5.12 BCC Calculation for calculation method of BCC and see Command Format for details about CMD and DATA.

Note that the processor sends a selecting block to set up the data type returned by the poll instruction.

2.5.9 Data Block

Data block is a block transmitted from the Unit to the Host. The content of the data block is shown in Figure 2.5. CMD, SIZE, DATA and BCC are identical to the selecting block described above.

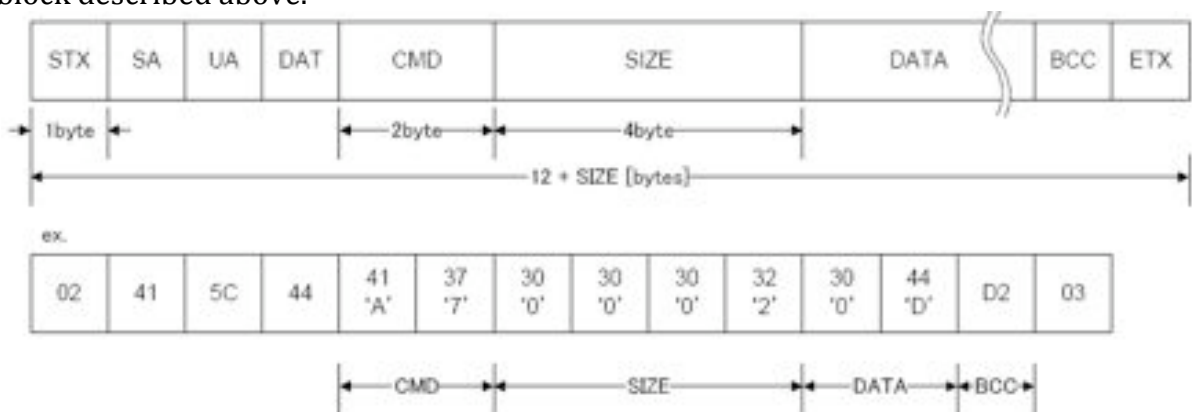

Figure 2.5 Transmission blocks of unit data

2.5.10 Acknowledge

Transmission block of acknowledge (ACK) is shown in Figure 2.6.

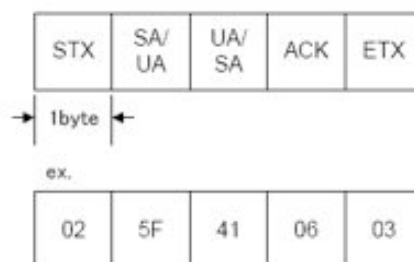

Figure 2.6 Transmission block of acknowledge

2.5.11 Negative Acknowledge

Transmission block of negative acknowledge (NAK) is shown in Figure 2.7.

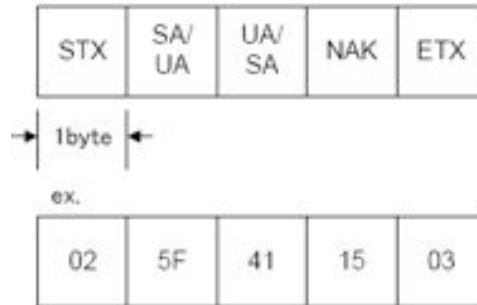

Figure 2.7 Transmission block of negative acknowledge

2.5.12 BCC Calculation

BCC is a check sum added when transmitting selecting block and data block. It specifies a calculated check sum of the shaded part in Figure 2.8 (CMD, SIZE and DATA) with 1 byte.

Figure 2.9 shows calculation method of BCC.

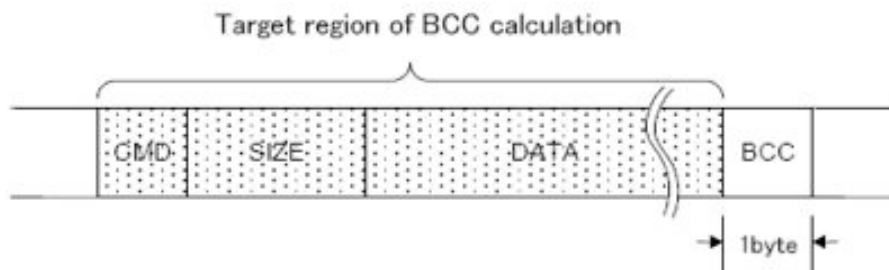

Figure 2.8 Data used for the BCC calculation



- i: location in the region of BCC calculation
- n: byte number in the region of BCC calculation
- DATA (i): data of ith byte
- MOD: remainder
- OR: logical sum

Figure 2.9: BCC calculation method

A BCC calculation example is shown in Figure 2.10 below.

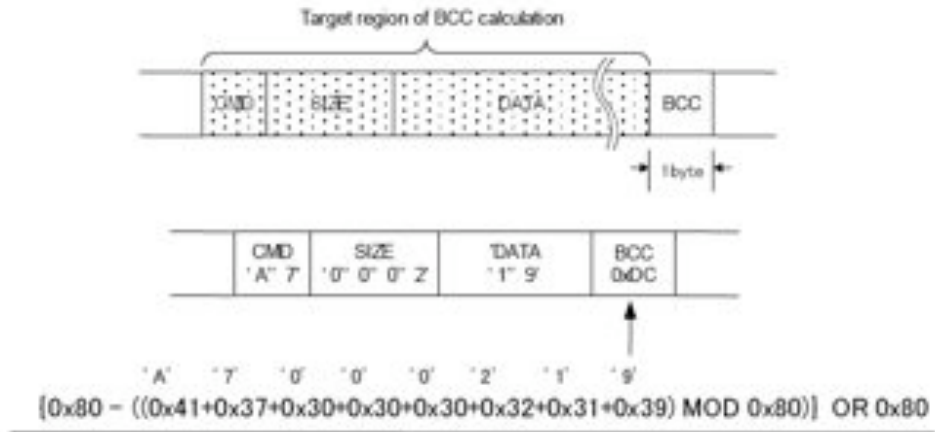

Figure 2.10 Example of BCC calculations

2.6 Communication Sequence

2.6.1 Polling Sequence

2.6.1.1 With Data Transmission

Figure 2.11 shows the sequence of data transmission to the Host processor for the polling sequence.

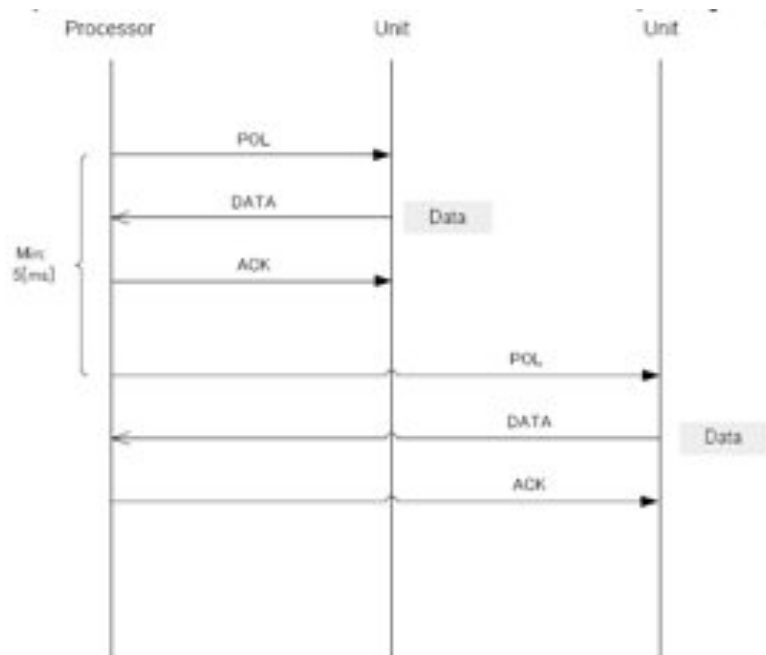

Figure 2.11 Polling sequence (with data transmission)

2.6.1.2 Without Data Transmission

Figure 2.12 shows the polling sequence when there is no data transmission to the Host processor. The unit sends a NAK when there is no data to be transmitted to the Host.

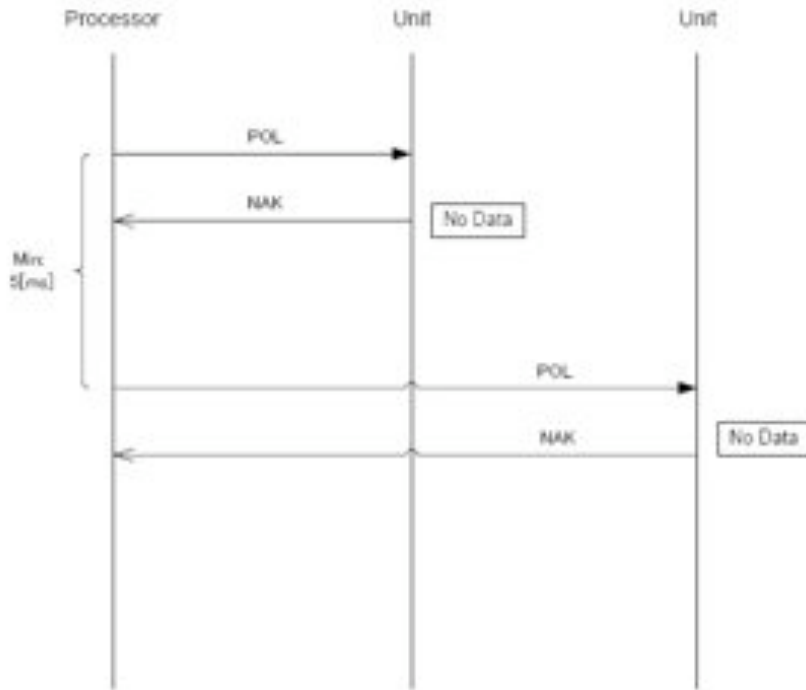

Figure 2.12 Polling sequence (without data transmission)

2.6.1.3 Timeout

Figure 2.13 shows the sequence in the event of no response to the POL transmission from the Host and Figure 2.14 shows sequence in the event of no response to the NAK transmission from Host.

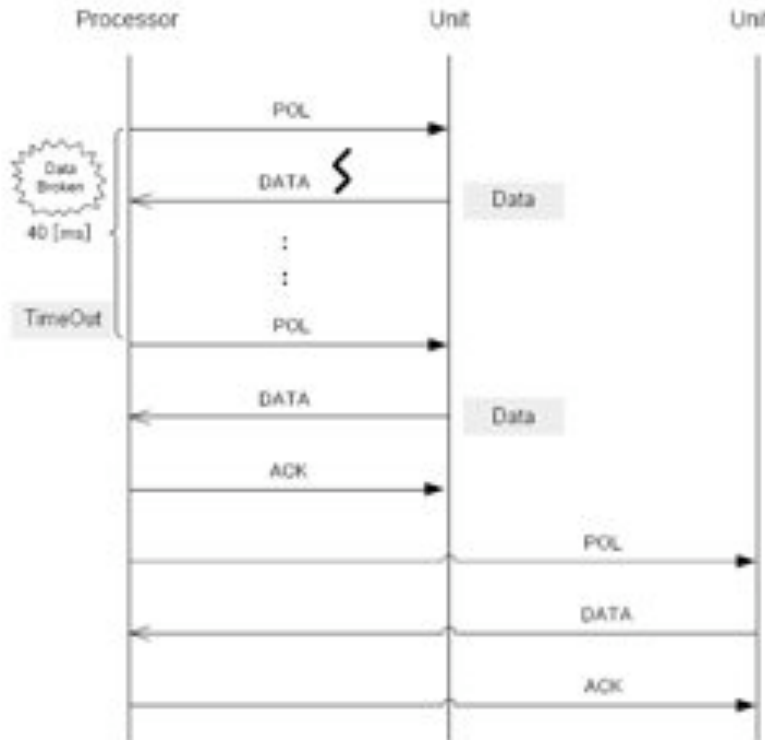

Figure 2.13 Polling sequence (timeout 1)

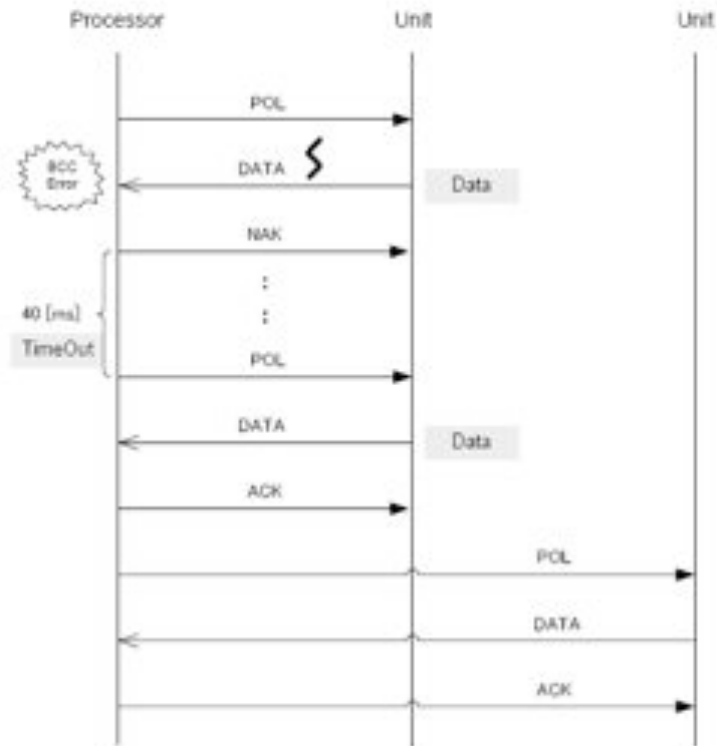

Figure 2.14 Polling sequence (timeout 2)

2.6.1.4 Retry

Figure 2.15 shows the sequence of data retransmission when data received from the unit is corrupted (BCC failure).

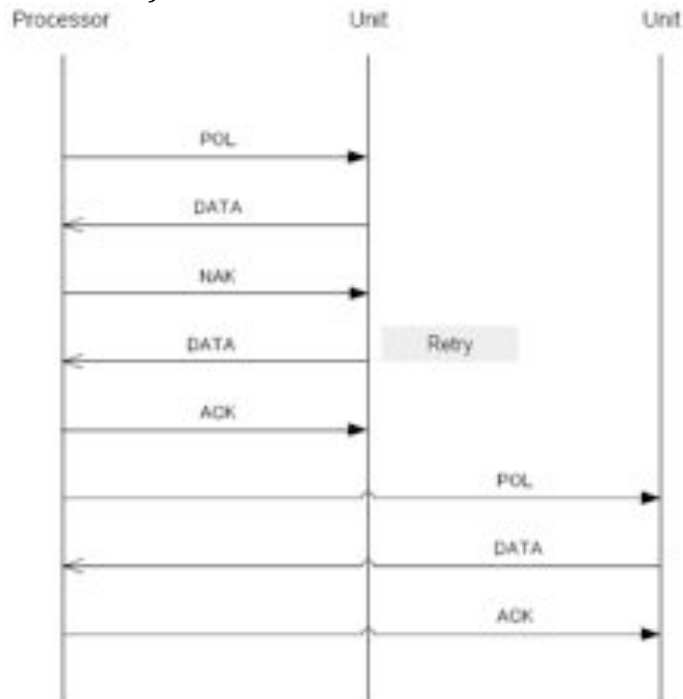

Figure 15 Polling sequence (Retry)

2.6.1.5 Excess Retry (BCC Failure)

Figure 2.16 shows the sequence in the event of multiple attempts at NAK transmission caused by BCC failure. The unit shall wait for the next polling sequence.

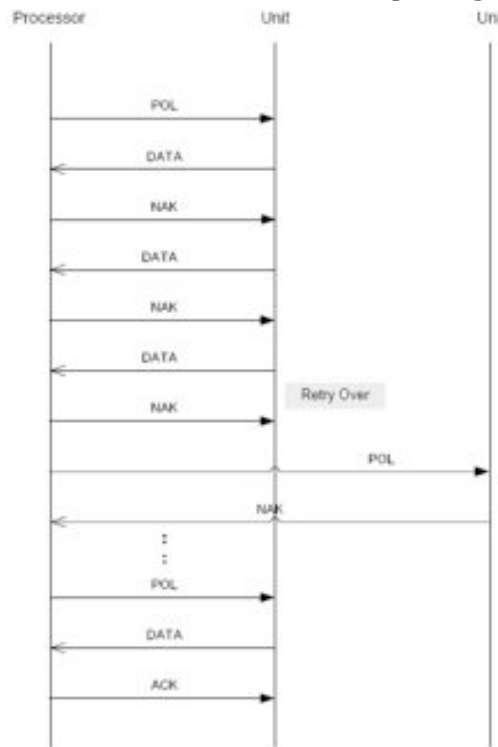

Figure 2.16 Polling sequence (excess retry by BCC failure)

2.6.1.6 Excess Retry (not-responding)

Figure 2.17 shows the sequence in the event of multiple attempts at POL transmission caused by a non-responsive Unit.

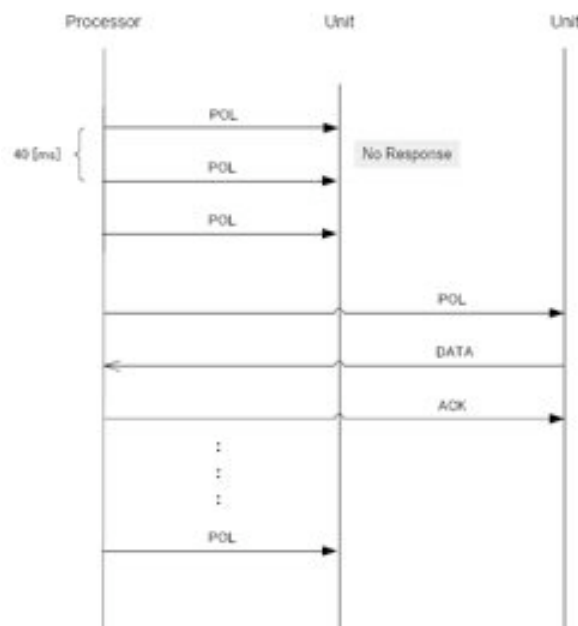

Figure 2.17 Polling sequence (excess retry)

2.6.1.7 Recovery from Transmission Failure

The host regards the unit with 'excess retry' as a communications failure (maybe the unit has lost the connection). After the next poll, the sequence process for recovery (waiting time of 10ms, no retry) shall be executed as shown in Figure 2.18.

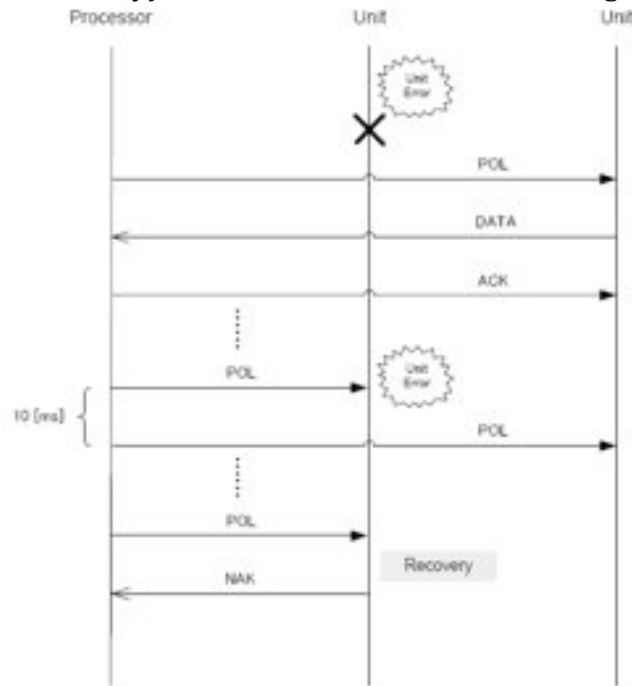

Figure 2.18 Recovery from Transmission Failure

2.6.2 Selecting Sequence

2.6.2.1 Data Transmission

Figure 2.19 shows the sequence of data transmission from Host to unit.

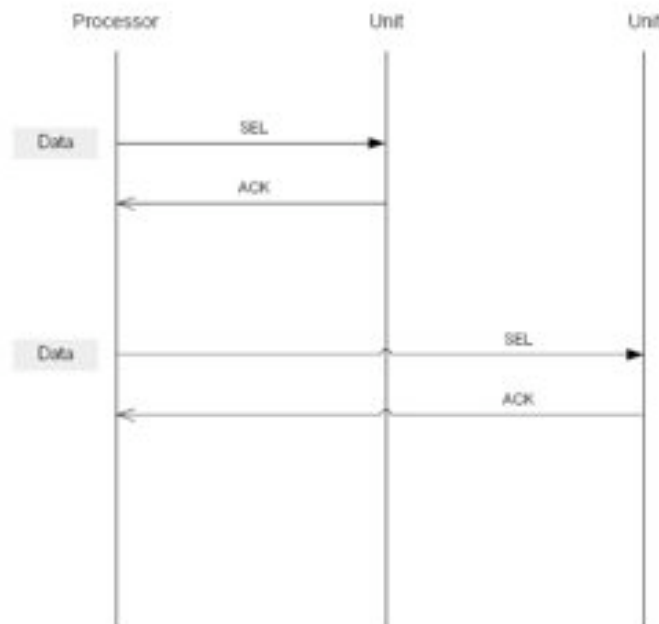

Figure 2.19 Selecting sequence (data transmission)

2.6.2.2 Retry

Figure 2.20 shows the sequence for data re-transmission when data received from the unit is corrupted (BCC failure).

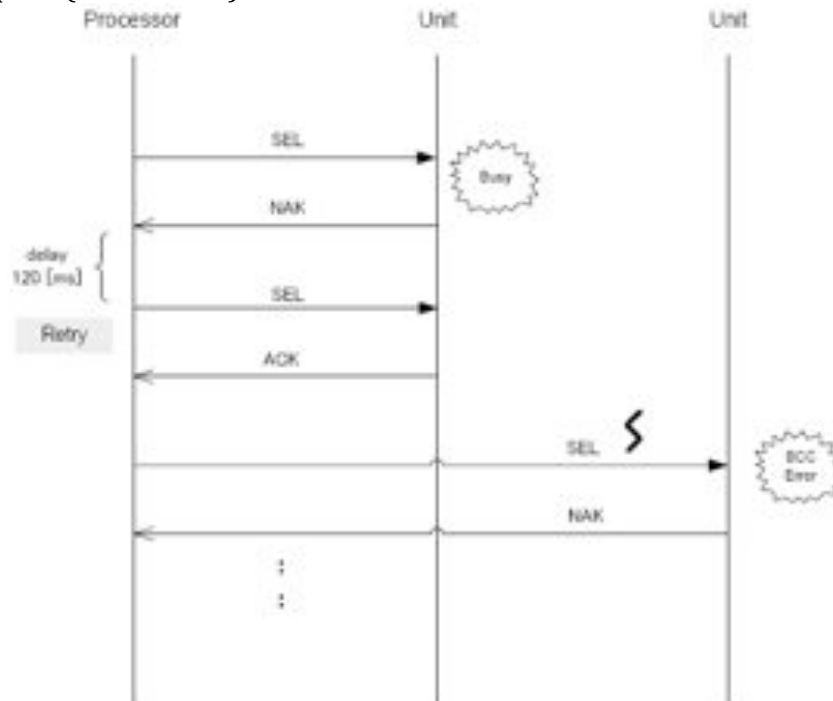

Figure 2.20 Selecting sequence (retry)

2.6.2.3 Excess Retry (BCC Failure)

Figure 2.21 shows the sequence in case of excess retry of data retransmission in the selecting sequence.

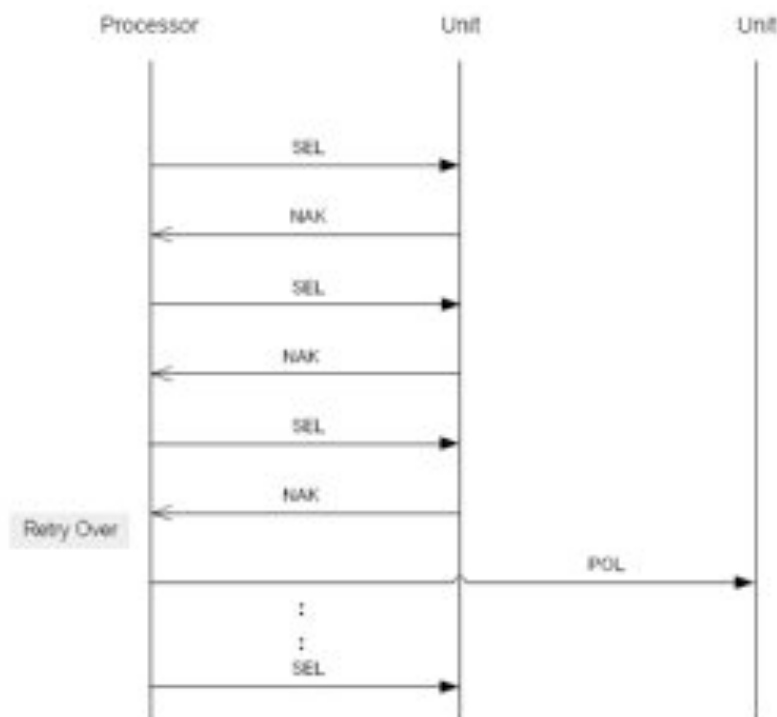

Figure 21 Selecting sequence (excess retry caused by BCC failure)

2.6.2.4 Excess Retry (not responding)

Figure 2.22 shows the sequence in the event of 'excess retry' of the SEL command transmission by a non-responsive unit.

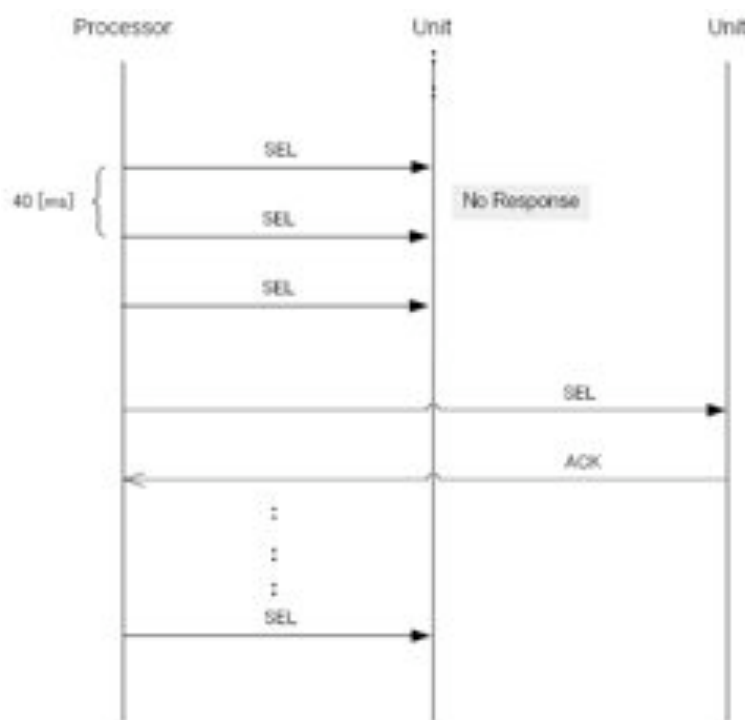

Figure 2.21 Selecting sequence (excess retry by nonresponding)

2.7 2.6 Amplifier Command Format

2.7.1 Amplifier DIP switch settings

Table 2.15 below shows the DIP switch settings

Action	DIP Switch
RS485 address bit 0	SW1
RS485 address bit 1	SW2
RS485 address bit 2	SW3
RS485 address bit 3	SW4
RS485 address bit 4	SW5
Master/Slave operation	SW6
RS485/Cobranet	SW7
38.4/115.2 kbits/sec	SW8

Table 2.15 DIP switch settings

Where...

SW1...SW5 set the 32 addresses for the amplifier

SW6 sets whether the amplifier is the master or slave
 SW7 sets whether the amplifier is connected to external devices, or to the optional cobranet accessory. In the Cobranet setting, the RS485 addresses are ignored.
 SW8 sets the RS485 port speed as 38.4 kbits/sec or 115.2 kbits/sec. The default setting is 115.2kbits/sec, but where the amplifier is in master mode and wall controls are more than 500meters away from the amplifier, the speed can be reduced to 38.4kbits/sec to extend the range to 1000meters.

Note: Internal amplifier bus only operates at 115.2 kbits/sec. External V-BUS can operate at 38.4 or 115.2 kbits/sec.

2.7.2 Amplifier Address number

The 32 possible amplifier addresses correspond to the DIP switch settings as follows

DIP Switch	V-BUS
00000	0x60
00001	0x61
00010	0x62
...	
11111	0x7F

Table 2.16 Amplifier Address

2.7.3 Amplifier Command numbers

Command numbers in the range shown in Table 2.17 is assigned to the command part "CMD" in transmission block (CMD) for every unit.

No.	Equipment	Range of command number
1	Reserved	---
2	Host	---
3	Reserved	0x40 ~ 0x4B
4	Reserved	0x4C~0x4F
5	Reserved	0x40 ~ 0x7F
6	V-BUS Amplifiers	0x80 ~ 0x9F
7	Reserved	0xA0 ~ 0xBF

Table 2.17 Range of command numbers assigned to amplifiers

Unit received polling from Host transmits command number and data block in data format corresponding to the command number to Host on a timely basis. Similarly, Host transmits command number assigned to every unit and selecting block in data format corresponding to the command number.

Details of command number of every unit and corresponding data format are described below.

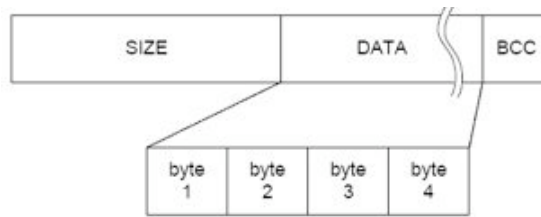

Figure 2.22 Data allocation example of command DATA part

2.7.4 Amplifier selecting Sequence (write)

An example of the communications between the Host processor and slave amplifier is given in Figure 2.23 below

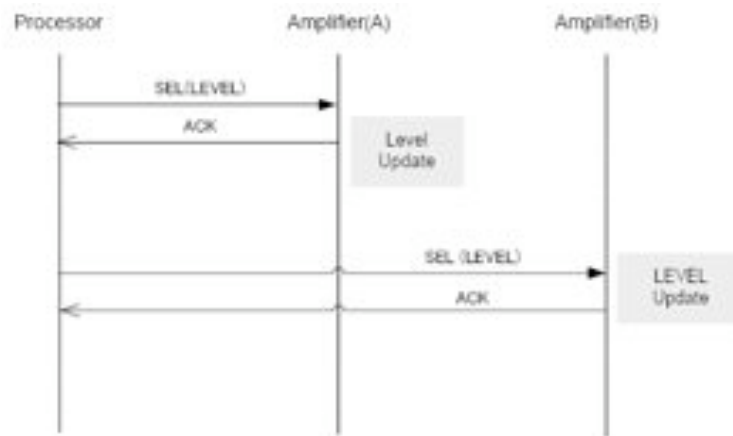

Figure 2.23 Control of Attenuation

2.7.5 Amplifier selecting sequence (read)

Due to the large amount of data, there are options for either reading all, or only particular sections of the amplifier settings and metrics. This is done as follows:

- Default power up is amplifier command 0x87, ie a global read command. If the host processor simply POL's the amplifier (see Figure 2.25 below), then the responding DATA will contain all possible amplifier settings and metrics, ie 242 bytes of data (if all 8 possible modules are present). The 242 bytes are made up of 224 bytes (28 bytes x 8 modules) from Table 2.3, plus 16 bytes from Table 2.4, plus 2 bytes defining which modules are present.
- The Host PC can modify the responding DATA, by sending a SEL instruction to the amplifier(s) prior to a POL instruction (see Figure 2.24 below). The SEL instruction will contain one of the commands from Table 17 (below), followed by qualifying bytes. The command will then instruct the amplifier to only respond with the DATA packet corresponding to that command. For example, if the SEL instruction is used to send command 0x82, then only attenuation data will be sent back from the amplifier on the next POL instruction.

Note: Different amplifiers can be set up with different SEL instructions. For example, amplifier 1 could be set up with a 0x82 command and amplifier 2 could

be set up with a 0x86 command. On the next POL instruction, amplifier 1 will respond with attenuation data only and amplifier 2 will respond with signal data only.

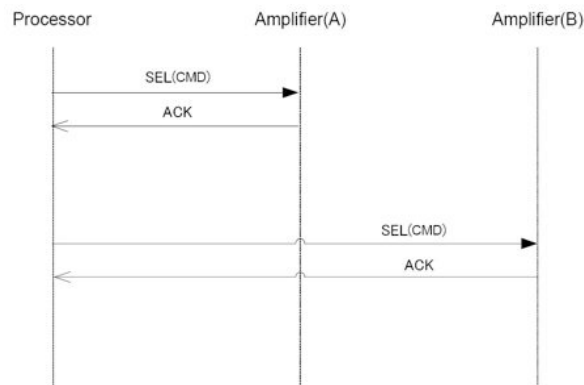

Figure 2.24 Using the SEL instruction to upload an amplifier DATA read command

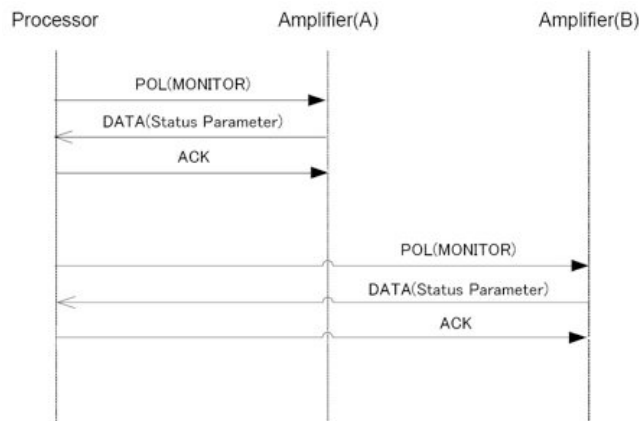

Figure 2.25: Using the POL instruction after the SEL instruction

- In addition to limiting the DATA packet to a particular type of data, the Host PC can apply a filter to limit the response to changed data only and certain amplifier modules only. The amplifier command will be accompanied by 3 data bytes, where byte 1 sets whether the DATA packet contains all data or only updated data and bytes 2 & 3 (ASCII format requires 2 bytes) sets which modules are to transmit in the DATA packet, as follows...
 - If byte 1 is set to 0 (ASCII 0x30), then all requested data will be sent for valid and available amplifier modules. If the amplifier modules are not present, then no data will be sent for that module, even if requested.
 - If byte 1 is set to 1 (ASCII 0x31), then only data that has changed since the last POL instruction will be sent. In this situation, Bytes 1 and 2 of the responding DATA packet will contain a mask on which valid and available modules are responding with changed data, ie bits 11111111 correspond to modules 1, 2 ...8 respectively.
 - If Byte 1 is set to 1 and no data has changed since the last POL, then the amplifier will respond with a NAK (see Figure 12).
 - Byte 2 & 3 are a switch (or mask) that determines which amplifier modules are to respond, where bits 11111111 correspond to modules 1,

2 ...8 respectively. For example if the Bits are 11001010 (Byte 2 = Hex 0C = ASCII 0x43 and Byte 3 = Hex 0A = ASCII 0x41), then only modules 1, 2, 5 & 7 will send data. However, if only the first 4 modules are present, then only modules 1 & 2 would respond to the POL instruction. Note: There is potential confusion relating to what is intended by "MODULEL" and "MODULEH". In the rest of the protocol, "H" and "L" indicates the high and low values of the parameter values, but for the amplifier modules "H" and "L" indicate the high and low slot numbers of the amplifier modules (Bit7 is amp module 1 and Bit0 is amp module 8).

Note: There are 6 types of signal, where each is treated slightly differently in terms of the POL of changed values. Otherwise key parameters may toggle between POL cycle and the user would have no indication of the changed state. These are

- Clip: Clip goes high until released by the next POL. It is important for the user to know if he/she is hitting momentary clip.
- SC/DC/FAULTM: Also goes high until released by the next POL. Otherwise momentary faults will not be recorded
- Temperature/VCC: Records the most recent value.
- Bridge/HPF: Rear panel controls, should not change, records the most recent value.
- Mute/ATT/CONTROLM: User controls-no issue-ideally the Host PC should have set these values and have them stored, so records the most recent value.
- MODEL/STATUSM: Should NOT change, so any change of status would indicate a fault, should indicate high until released by the next POL.
- Signal changes since the last POL: Record peak value changes

2.7.6 Amplifier command set (Slave Mode)

Commands sent/received between Host and Slave Amplifier are listed in Table 2.18.

Slave Command	Number
Attenuation Write	0x80
Control Write	0x81
Attenuation Read	0x82
Control Read	0x83
Status Read	0x84
Temperature Read	0x85
Signal Read	0x86
Global Read	0x87
Firmware revision Read	0x8E
Firmware Write	0x8F

Table 2.18 Amplifier commands

Note: Firmware revision read is not included in the Global data packet and must be read though an individual SEL/POL sequence.

2.7.7 Attenuation Write Command

Attenuation data format is described below...



Where...

“CMD” = 0x80, in ASCII format, ie Byte 1 = ASCII “38”, Byte 2 = ASCII “30”

“SIZE” = 0x06..0x21, ie 6-34 bytes of data (again written in ASCII) for 1-8 amplifier modules.

“DATA”: Bytes 1 & 2 = ASCII 0x00...0xFF, where the bit map (11111111) determines which amplifier modules are set by to the SEL instruction. Bytes 3...34 are a string (again written in ASCII), where byte addresses 3 & 4 are channel 1 attenuation, 5 & 6 are channel 2 attenuation, etc, as shown in table 2.19 below.

For less than 8 amplifier modules, then the MODULE data, SIZE value and DATA packet will reduce to reflect the smaller number of modules.

Name	Address	ASCII	Name	Address	ASCII
MODULEL	0x00	Byte 1	ATT9L	0x12	Byte 1
MODULEH	0x01	Byte 2	ATT9H	0x13	Byte 2
ATT1L	0x02	Byte 1	ATT10L	0x14	Byte 1
ATT1H	0x03	Byte 2	ATT10H	0x15	Byte 2
ATT2L	0x04	Byte 1	ATT11L	0x16	Byte 1
ATT2H	0x05	Byte 2	ATT11H	0x17	Byte 2
ATT3L	0x06	Byte 1	ATT12L	0x18	Byte 1
ATT3H	0x07	Byte 2	ATT12H	0x19	Byte 2
ATT4L	0x08	Byte 1	ATT13L	0x1A	Byte 1
ATT4H	0x09	Byte 2	ATT13H	0x1B	Byte 2
ATT5L	0x0A	Byte 1	ATT14L	0x1C	Byte 1
ATT5H	0x0B	Byte 2	ATT14H	0x1D	Byte 2
ATT6L	0x0C	Byte 1	ATT15L	0x1E	Byte 1
ATT6H	0x0D	Byte 2	ATT15H	0x1F	Byte 2
ATT7L	0x0E	Byte 1	ATT16L	0x20	Byte 1
ATT7H	0x0F	Byte 2	ATT16H	0x21	Byte 2
ATT8L	0x10	Byte 1			
ATT8H	0x11	Byte 2			

Table 2.19 Command 0x80 Attenuation write.

2.7.8 Control Write Command

Control data format is described below...



Where...

“CMD” = 0x81, in ASCII format, ie Byte 1 = ASCII “38”, Byte 2 = ASCII “31”

“SIZE” = 0x04..0x0A, ie 4-11 bytes of data (again written in ASCII) for 1-8 amplifier modules.

“DATA”: Bytes 1 & 2 = ASCII 0x00...0xFF, where the bit map (11111111) determines which amplifier modules are set by to the SEL instruction. Bytes 3...11 are a string (again written in ASCII), where byte address 3 is the master comms module control, byte 4 is amplifier module 1 controls, etc, as shown in table 2.20 below.

Name	Address	ASCII
MODULEL	0x00	Byte 1
MODULEH	0x01	Byte 2
CONTROLM	0x02	Byte 1
CONTROL1	0x03	Byte 1
CONTROL2	0x04	Byte 1
CONTROL3	0x05	Byte 1
CONTROL4	0x06	Byte 1
CONTROL5	0x07	Byte 1
CONTROL6	0x08	Byte 1
CONTROL7	0x09	Byte 1
CONTROL8	0x0A	Byte 1

Table 2.20 Command 0x80 Attenuation write

Again, for less than 8 amplifier modules, then the Module data, SIZE value and DATA size will reduce to reflect the small number of modules.

2.7.9 Attenuation read Command

In order to read attenuation only, a SEL instruction must be sent to the target amplifier(s) prior to a POL instruction. The amplifier will then respond to subsequent POL instruction with a modified DATA packet. The effects of the SEL instruction are given below...



Where...

“CMD” = 0x82, in ASCII format, ie Byte 1 = ASCII “38”, Byte 2 = ASCII “32”

“SIZE” = 0x03, ie 3 bytes (ASCII = “33”)

“DATA”, where...

Byte 1 = 0 (ASCII “30”) “ie send all requested parameters, or 1 (ASCII “31”), ie only send those parameters that have changed since the last POL

Bytes 2 & 3 = 0x00...0xFF in ASCII, where the bit map (11111111) determines which amplifier modules reply to the POL instruction.

If Byte 1 = 0 and Bytes 2 & 3 = 0xFF (11111111), then all *available* modules will respond with data (changed or not since the last POL), eg if Bytes 2 & 3 = 0xFF, but only modules 1 & 2 are present and available, then only data for modules 1 & 2 will be transmitted

The data format for command 0x82 is described below



Where...

“CMD” = 0x82, in ASCII format, ie Byte 1 = ASCII “38”, Byte 2 = ASCII “32”

“SIZE” = 0x06..0x22, ie 6-34 bytes of data (again written in ASCII) for 1-8 amplifier modules.

“DATA” (ASCII) will be a sequence as follows (see Table 18 above). If byte 1 = 0, then a NAK is transmitted.

Bytes 1 & 2 = Bit map (11111111) and determines which amplifier modules have replied to the POL instruction.

Bytes 3...34 are the pairs of bytes (in ASCII) corresponding to the attenuation of the 16 possible amplifier channels.

For example, if amplifier modules 1, 2, 3 are present, but only module 2 has changed data since the last POL...

- If SEL has set up command 0x82 to POL all data: Bytes 1 & 2 would show modules 1, 2, 3 presenting data and transmit 14 bytes of data
- If SEL has set up command 0x82 to POL changed data: Byte 1 would show module 2 presenting data and transmit 6 bytes of data (the minimum)

2.7.10 Control read command

In order to read control status only, a SEL instruction must be sent to the target amplifier(s) prior to a POL instruction. The amplifier will then respond to subsequent POL instruction with a modified DATA packet. The effects of the SEL instruction are given below...



Where...

“CMD” = 0x83, in ASCII format, ie Byte 1 = ASCII “38”, Byte 2 = ASCII “33”

“SIZE” = 0x03, ie 3 bytes (ASCII = “33”)

“DATA”, where...

Byte 1 = 0 (ASCII “30”) “ie send all requested parameters, or 1 (ASCII “31”), ie only send those parameters that have changed since the last POL

Bytes 2 & 3 = 0x00...0xFF in ASCII, where the bit map (11111111) determines which amplifier modules reply to the POL instruction.

If Byte 1 = 0 and Bytes 2 & 3 = 0xFF (11111111), then all *available* modules will respond with data (changed or not since the last POL), eg if Bytes 2 & 3 = 0xFF, but only modules 1 & 2 are present and available, then only data for modules 1 & 2 will be transmitted

The data format for command 0x83 is described below



Where...

“CMD” = 0x83, in ASCII format, ie Byte 1 = ASCII “38”, Byte 2 = ASCII “33”

“SIZE” = 0x04..0x0B, ie 4-11 bytes of data (again written in ASCII) for 1-8 amplifier modules.

“DATA” (ASCII) will be a sequence as follows (see Table 19 above).

Bytes 1 & 2 = Bit map (11111111) and determines which amplifier modules have replied to the POL instruction.

Byte 3 corresponds to the control status of the SMPS

Bytes 4...11 are the bytes corresponding to the control status of the 8 possible amplifier modules.

For example, if amplifier modules 1, 2, 3 & 4 are present, but only modules 3 & 4 has changed data since the last POL...

- If SEL has set up command 0x83 to POL all data: Bytes 1 & 2 would show modules 1, 2, 3, & 4 presenting data and transmit 7 bytes of data
- If SEL has set up command 0x83 to POL changed data: Bytes 1 & 2 would show modules 3 & 4 presenting data and transmit 5 bytes of data

Note that Control status for the SMPS is always provided and thus there will not be a NAK for the control status response.

2.7.11 Status Read Command

In order to read operational status only, a SEL instruction must be sent to the target amplifier(s) prior to a POL instruction. The amplifier will then respond to subsequent POL instruction with a modified DATA packet. The effects of the SEL instruction are given below...



Where...

“CMD” = 0x84, in ASCII format, ie Byte 1 = ASCII “38”, Byte 2 = ASCII “34”

“SIZE” = 0x03, ie 3 bytes (ASCII = “33”)

“DATA”, where...

Byte 1 = 0 (ASCII “30”) “ie send all requested parameters, or 1 (ASCII “31”), ie only send those parameters that have changed since the last POL

Bytes 2 & 3 = 0x00...0xFF in ASCII, where the bit map (11111111) determines which amplifier modules reply to the POL instruction.

If Byte 1 = 0 and Bytes 2 & 3 = 0xFF (11111111), then all *available* modules will respond with data (changed or not since the last POL), eg if Bytes 2 & 3 = 0xFF, but only modules 1 & 2 are present and available, then only data for modules 1 & 2 will be transmitted

The data format for command 0x84 is described below



Where...

“CMD” = 0x84, in ASCII format, ie Byte 1 = ASCII “38”, Byte 2 = ASCII “34”

“SIZE” = 0x11...0x26, ie up to 38 bytes of data (again written in ASCII)

“DATA” (ASCII) will be a sequence as follows (see Table 18 below).

Bytes 1 & 2 = Bit map (11111111) and determines which amplifier modules have replied to the POL instruction

Bytes 3...14 are the 12 bytes corresponding to the SMPS

Bytes 15...38 are the 24 bytes corresponding to the operational status of 8 possible amplifier modules.

For example, if amplifier modules 1 & 2 are present, and both modules have changed data since the last POL...

- If SEL has set up command 0x84 to POL all data: Bytes 1 & 2 would show modules 1 & 2 presenting data and provide 20 bytes of data
- If SEL has set up command 0x84 to POL changed data: Byte 1 would show modules 1 & 2 presenting data and provide 20 bytes of data

Note that Status for the SMPS is always provided and thus there will not be a NAK for the control status response

Name	Address	ASCII	Name	Address	ASCII
MODULEL	0x00	Byte 1	FAULT3L	0x14	Byte 1
MODULEH	0x01	Byte 2	FAULT3H	0x15	Byte 2
VCC5L	0x02	Byte 1	STATUS3	0x16	Byte 1
VCC5H	0x03	Byte 2	FAULT4L	0x17	Byte 1
VCC15L	0x04	Byte 1	FAULT4H	0x18	Byte 2
VCC15H	0x05	Byte 2	STATUS4	0x19	Byte 1
VCCAMPL	0x06	Byte 1	FAULT5L	0x1A	Byte 1
VCCAMPH	0x07	Byte 2	FAULT5H	0x1B	Byte 2
MODEL	0x08	Byte 1	STATUS5	0x1C	Byte 1
MODEL	0x09	Byte 2	FAULT6L	0x1D	Byte 1
FAULTM	0x0A	Byte 1	FAULT6H	0x1E	Byte 2
CONTROLM	0x0B	Byte 1	STATUS6	0x1F	Byte 1
STATUSM	0x0C	Byte 1	FAULT7L	0x20	Byte 1
STATUSM	0x0D	Byte 2	FAULT7H	0x21	Byte 2
FAULT1L	0x0E	Byte 1	STATUS7	0x22	Byte 1
FAULT1H	0x0F	Byte 2	FAULT8L	0x23	Byte 1
STATUS1	0x10	Byte 1	FAULT8H	0x24	Byte 2
FAULT2L	0x11	Byte 1	STATUS8	0x25	Byte 1
FAULT2H	0x12	Byte 2			
STATUS2	0x13	Byte 1			

Table 2.21 Status Read Dataset.

2.7.12 Temperature Read Command

In order to read temperature only, a SEL instruction must be sent to the target amplifier(s) prior to a POL instruction. The amplifier will then respond to subsequent POL instruction with a modified DATA packet. The effects of the SEL instruction are given below...



Where...

“CMD” = 0x85, in ASCII format, ie Byte 1 = ASCII “38”, Byte 2 = ASCII “35”

“SIZE” = 0x03, ie 3 bytes (ASCII = “33”)

“DATA”, where...

Byte 1 = 0 (ASCII “30”) “ie send all requested parameters, or 1 (ASCII “31”), ie only send those parameters that have changed since the last POL

Bytes 2 & 3 = 0x00...0xFF in ASCII, where the bit map (11111111) determines which amplifier modules reply to the POL instruction.

If Byte 1 = 0 and Bytes 2 & 3 = 0xFF (11111111), then all *available* modules will respond with data (changed or not since the last POL), eg if Bytes 2 & 3 = 0xFF, but only modules 1 & 2 are present and available, then only data for modules 1 & 2 will be transmitted

The data format for command 0x85 is described below



Where...

“CMD” = 0x85, in ASCII format, ie Byte 1 = ASCII “38”, Byte 2 = ASCII “35”

“SIZE” = 0x08...0x16, ie up to 22 bytes of data (again written in ASCII)

“DATA” (ASCII) will be a sequence as follows (see Table 19 below).

Bytes 1 & 2 = Bit map (11111111) and determines which amplifier modules have replied to the POL instruction

Bytes 3...6 are the 4 bytes corresponding to the SMPS/PFC temperature

Bytes 7...22 are the 16 bytes corresponding to the temperature status of 8 possible amplifier modules.

For example, if amplifier modules 1 & 2 are present, and both modules have changed data since the last POL...

- If SEL has set up command 0x85 to POL all data: Bytes 1 & 2 would show modules 1 & 2 presenting data and provide 10 bytes of data
- If SEL has set up command 0x85 to POL changed data: Byte 1 would show modules 1 & 2 presenting data and provide 10 bytes of data

Note that temperature for the SMPS is always provided and thus there will not be a NAK for the temperature read response

The dataset is shown in Table 2.22 below, where 0x00/0x01 are the bytes showing the number of modules present, 0x02 is the low data byte of an 8 bit temperature signal for the PFC module, etc...

Name	Address	ASCII	Name	Address	ASCII
MODULEL	0x00	Byte 1	TEMP4L	0x0C	Byte 1
MODULEH	0x01	Byte 2	TEMP4H	0x0D	Byte 2
PFCTML	0x02	Byte 1	TEMP5L	0x0E	Byte 1
PFCTMH	0x03	Byte 2	TEMP5H	0x0F	Byte 2
SMPSTML	0x04	Byte 1	TEMP6L	0x10	Byte 1
SMPSTMH	0x05	Byte 2	TEMP6H	0x11	Byte 2
TEMP1L	0x06	Byte 1	TEMP7L	0x12	Byte 1
TEMP1H	0x07	Byte 2	TEMP7H	0x13	Byte 2
TEMP2L	0x08	Byte 1	TEMP8L	0x14	Byte 1
TEMP2H	0x09	Byte 2	TEMP8H	0x15	Byte 2
TEMP3L	0x0A	Byte 1			
TEMP3H	0x0B	Byte 2			

Table 2.22 Temperature read dataset

2.7.13 Signal Read Command

In order to read signal only, a SEL instruction must be sent to the target amplifier(s) prior to a POL instruction. The amplifier will then respond to subsequent POL instruction with a modified DATA packet. The effects of the SEL instruction are given below...



Where...

“CMD” = 0x86, in ASCII format, ie Byte 1 = ASCII “38”, Byte 2 = ASCII “36”

“SIZE” = 0x03, ie 3 bytes (ASCII = “33”)

“DATA”, where...

Byte 1 = 0 (ASCII "30") "ie send all requested parameters, or 1 (ASCII "31"), ie only send those parameters that have changed since the last POL
 Bytes 2 & 3 = 0x00...0xFF in ASCII, where the bit map (11111111) determines which amplifier modules reply to the POL instruction.

If Byte 1 = 0 and Bytes 2 & 3 = 0xFF (11111111), then all *available* modules will respond with data (changed or not since the last POL), eg if Bytes 2 & 3 = 0xFF, but only modules 1 & 2 are present and available, then only data for modules 1 & 2 will be transmitted. The data format for command 0x86 is described below



Where...

"CMD" = 0x86, in ASCII format, ie Byte 1 = ASCII "38", Byte 2 = ASCII "36"
 "SIZE" = 0x14...0x92, ie up to 146 bytes of data (again written in ASCII).
 "DATA" (ASCII) will be a sequence as follows (see Table 20 below). If byte 1 = 0, then a NAK is transmitted...

Bytes 1 & 2 = Bit map (11111111) and determines which amplifier modules have replied to the POL instruction
 Bytes 3...146 are the 8 sets of 18 bytes corresponding to the signal condition of the 8 possible amplifier modules.

For example, if amplifier modules 1, 2, 3 are present, but only module 2 has changed data since the last POL...

- If SEL has set up command 0x86 to POL all data: Bytes 1 & 2 would show modules 1, 2, 3 presenting data and transmit 56 bytes of data
- If SEL has set up command 0x86 to POL changed data: Bytes 1 & 2 would show module 2 presenting data and transmit 20 bytes of data (the minimum)

Name	Address	ASCII	Name	Address	ASCII
MODULEL	0x00	Byte 1		
MODULEH	0x01	Byte 2		
SIG1PEL	0x02	Byte 1	SIG15PEL	0x82	Byte 1
SIG1PEH	0x03	Byte 2	SIG15PEH	0x83	Byte 2
SIG1POL	0x04	Byte 1	SIG15POL	0x84	Byte 1
SIG1POH	0x05	Byte 2	SIG15POH	0x85	Byte 2
SIG2PEL	0x06	Byte 1	SIG16PEL	0x86	Byte 1
SIG2PEH	0x07	Byte 2	SIG16PEH	0x87	Byte 2
SIG2POL	0x08	Byte 1	SIG16POL	0x88	Byte 1
SIG2POH	0x09	Byte 2	SIG16POH	0x89	Byte 2

OCUR1L	0x0A	Byte 1	OCUR15L	0x8A	Byte 1
OCUR1H	0x0B	Byte 2	OCUR15H	0x8B	Byte 2
OCUR2L	0x0C	Byte 1	OCUR16L	0x8C	Byte 1
OCUR2H	0x0D	Byte 2	OCUR16H	0x8D	Byte 2
OVOL1L	0x0E	Byte 1	OVOL15L	0x8E	Byte 1
OVOL1H	0x0F	Byte 2	OVOL15H	0x8F	Byte 2
OVOL2L	0x10	Byte 1	OVOL16L	0x90	Byte 1
OVOL2H	0x11	Byte 2	OVOL16H	0x91	Byte 2
HIGH BITS L	0x12	Byte 1	HIGH BITS L	0x92	Byte 1
HIGH BITS H	0x13	Byte 2	HIGH BITS H	0x93	Byte 2

Table 2.23 Signal dataset

Note: Bit stuffing is involved for the output voltage and current, where the high bits (bits 9 & 10) of each sequence of 4 bytes are stuffed into the 5th byte. For example, bits 9 & 10 for OCUR1 are bits 1 & 2 of the 5th byte, bits 9 & 10 for OCUR2 are bits 3 & 4, of the 5th byte and so on.

2.7.14 Global read command

This is the default DATA packet, ie if no SEL instructions are used to limit the size of the data packet, the amplifier will respond with a 242 byte data string.

The SEL instruction can be used to limit the size of the global read command. To do this, the SEL instruction must be sent to the target amplifier(s) prior to a POL instruction. The amplifier will then respond to subsequent POL instruction with a modified DATA packet. The effects of the SEL instruction are given below...



Where...

“CMD” = 0x87, in ASCII format, ie Byte 1 = ASCII “38”, Byte 2 = ASCII “37”

“SIZE” = 0x03, ie 3 bytes (ASCII = “33”)

“DATA”, where...

Byte 1 = 0 (ASCII “30”) “ie send all requested parameters, or 1 (ASCII “31”), ie only send those parameters that have changed since the last POL

Bytes 2 & 3 = 0x00...0xFF in ASCII, where the bit map (11111111) determines which amplifier modules reply to the POL instruction.

If Byte 1 = 0 and Bytes 2 & 3 = 0xFF (11111111), then all *available* modules will respond with data (changed or not since the last POL), eg if Bytes 2 & 3 = 0xFF, but only modules 1 & 2 are present and available, then only data for modules 1 & 2 will be transmitted

The data format for command 0x87 is described below



Where...

“CMD” = 0x87, in ASCII format, ie Byte 1 = ASCII “38”, Byte 2 = ASCII “37”

“SIZE” = 0x2e...0xF3, ie up to 242 bytes of data (again written in ASCII)

“DATA” (ASCII) will be a sequence as follows

Bytes 1 & 2 = Bit map (11111111) and determines which amplifier modules have replied to the POL instruction

Bytes 3...18 are the bytes corresponding to the SMPS

19...242 are the 8 sets of 28 bytes corresponding to the 8 possible amplifier modules.

Name	Address	ASCII	Name	Address	ASCII
MODULEL	0x00	Byte 1	ATT1L	0x26	Byte 1
MODULEH	0x01	Byte 2	ATT1H	0x27	Byte 2
VCC5L	0x02	Byte 1	ATT2L	0x28	Byte 1
VCC5H	0x03	Byte 2	ATT2H	0x29	Byte 2
VCC15L	0x04	Byte 1	FAULT1L	0x2A	Byte 1
VCC15H	0x05	Byte 2	FAULT1H	0x2B	Byte 2
VCCAMPL	0x06	Byte 1	STATUS1	0x2C	Byte 1
VCCAMPH	0x07	Byte 2	CONTROL1	0x2D	Byte 1
MODEL	0x08	Byte 1		
MODEL	0x09	Byte 2		
PFCTML	0x0A	Byte 1	SIG15PEL	0xD7	Byte 1
PFCTMH	0x0B	Byte 2	SIG15PEH	0xD8	Byte 2
SMPSTML	0x0C	Byte 1	SIG15POL	0xD9	Byte 1
SMPSTMH	0x0D	Byte 2	SIG15POH	0xDA	Byte 2
FAULTM	0x0E	Byte 1	SIG16PEL	0xDB	Byte 1
CONTROLM	0x0F	Byte 1	SIG16PEH	0xDC	Byte 2
STATUSM	0x10	Byte 1	SIG16POL	0xDD	Byte 1
STATUSM	0x11	Byte 2	SIG16POH	0xDE	Byte 2
SIG1PEL	0x12	Byte 1	OCUR15L	0xDF	Byte 1
SIG1PEH	0x13	Byte 2	OCUR15H	0xE0	Byte 2
SIG1POL	0x14	Byte 1	OCUR16L	0xE1	Byte 1
SIG1POH	0x15	Byte 2	OCUR16H	0xE2	Byte 2
SIG2PEL	0x16	Byte 1	OVOL15L	0xDE3	Byte 1
SIG2PEH	0x17	Byte 2	OVOL15H	0xE4	Byte 2
SIG2POL	0x18	Byte 1	OVOL16L	0xE5	Byte 1
SIG2POH	0x19	Byte 2	OVOL16H	0xE6	Byte 2
OCUR1L	0x1A	Byte 1	HIGH BITS L	0xE7	Byte 1
OCUR1H	0x1B	Byte 2	HIGH BITS H	0xE8	Byte 2
OCUR2L	0x1C	Byte 1	TEMP8L	0xE9	Byte 1
OCUR2H	0x1D	Byte 2	TEMP8H	0xEA	Byte 2
OVOL1L	0x1E	Byte 1	ATT15L	0xEB	Byte 1
OVOL1H	0x1F	Byte 2	ATT15H	0xEC	Byte 2
OVOL2L	0x20	Byte 1	ATT16L	0xED	Byte 1
OVOL2H	0x21	Byte 2	ATT16H	0xEE	Byte 2
HIGH BITS L	0x22	Byte 1	FAULT8L	0xEF	Byte 1
HIGH BITS H	0x23	Byte 2	FAULT8H	0xF0	Byte 2
TEMP1L	0x24	Byte 1	STATUS8	0xF1	Byte 1
TEMP1H	0x25	Byte 2	CONTROL8	0xF2	Byte 1

Table 2.24 Global dataset

For example, if amplifier modules 1, 2, 3 are present, but only module 2 has changed data since the last POL...

- If SEL has set up command 0x87 to POL all data: Byte 1 would show modules 1, 2, 3 presenting data and transmit 102 bytes of data
- If SEL has set up command 0x87 to POL changed data: Byte 1 would show module 2 presenting data and transmit 46 bytes of data (the minimum).

Note that Control status for the SMPS is always provided and thus there will not be a NAK for the global read response

Table 23 above shows where 0x00 is the byte showing the number of modules present, byte address 0x01 is the data byte of an 8bit voltage signal for the SMPS 5volt voltage rail, etc...

Note: Bit stuffing is involved for the output voltage and current, where the high bits (bits 9 & 10) of each sequence of 4 bytes are stuffed into the 5th byte. For example, bits 9 & 10 for OCUR1 are bits 1 & 2 of the 5th byte, bits 9 & 10 for OCUR2 are bits 3 & 4, of the 5th byte and so on.

2.8 Amplifier commands (Amplifier as master)

TBA

2.9 Hardware interfacing

2.9.1 RS485: Basics

RS-485 is a bi-directional half-duplex multidrop network using a twisted pair cable. Multidrop implies that multiple transceivers (transmitter and receiver in the same device) may be connected to the line. However, only one transmitter may be active at any given time. Data can flow from any single transceiver (which is transmitting) to one or more transceivers (that are receiving). In contrast, a full-duplex bus, supports simultaneous data flow in both directions. RS-485 is sometimes thought (mistakenly) to be a full-duplex bus because it supports bidirectional data transfer. However, simultaneous bidirectional transfers require not one but two data pairs.

RS-485 transmission lines are differential in nature. There are two wires, A and B. The driver generates complementary voltages on A and B to achieve a differential signal. Transceivers have the ability to tri-state (hi impedance) both A and B.

Receivers are designed to respond to the difference between A and B. The differential voltage should be > 200-mV difference between A and B. Anything less than 200 mV will result in an indeterminate result and corrupted data.

RS-485 can support networks up to 5000' long and bit rates of up to 10 Mbps. Data rate must be traded off against cable length. Figure 2.26 shows a graph fairly typical of the

bit rates and line lengths you can expect.

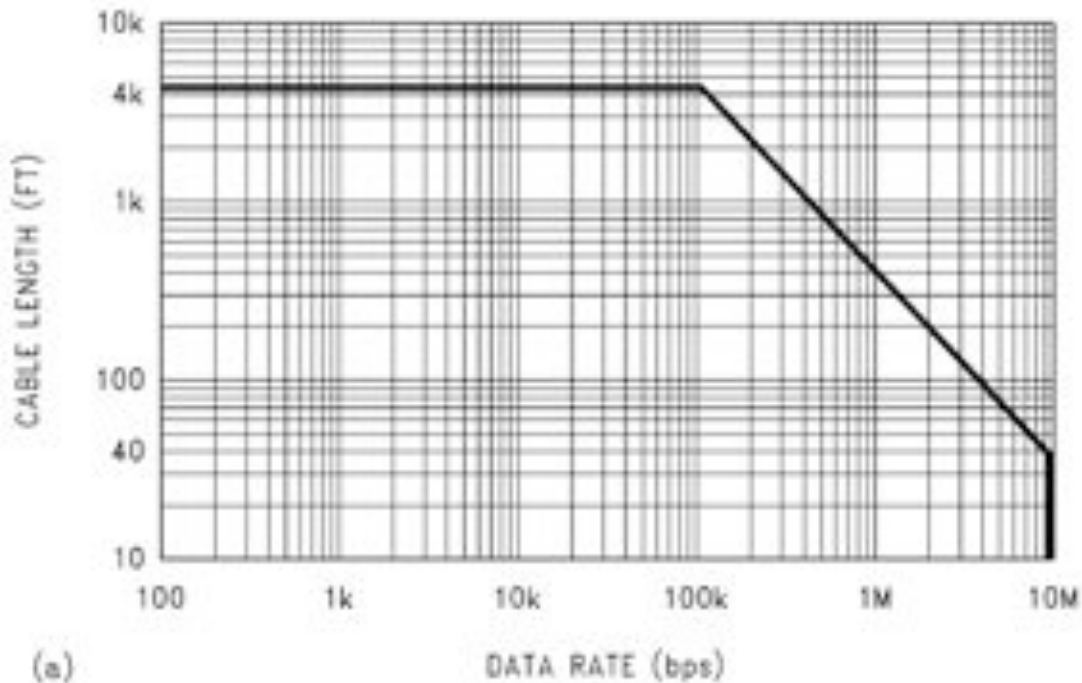

Figure 2.26: Cable vs data rate. MTS amplifiers operate at 115kbps

The TIA/EIA-485-A specification defines a load and states that an RS-485 line driver must be able to drive 32 loads. However, an RS-485 network can support more than 32 nodes, but ONLY if each node uses $\frac{1}{4}$ (or less) load driver devices. The MTS amplifiers are designed to permit up to 64 channels on any single system. It does not matter if there are 8 amplifiers x 8 channels or 32 amplifiers x 2 channels. However, the load is limited to 32 standard load devices.

Multiple networks can be chained together using repeaters to accommodate virtually an unlimited number of nodes. However care must be taken to accommodate the propagation delays in large networks with multiple repeaters and long transmission lines, and the data rate may become unacceptably low.

RS485 network configuration is important. Although all of the topologies shown in Figure 2.27 will work, you should avoid the ones in (a), (c), and (e). Those in (b), (d), and (f), offer much better performance and will suffer less data loss.

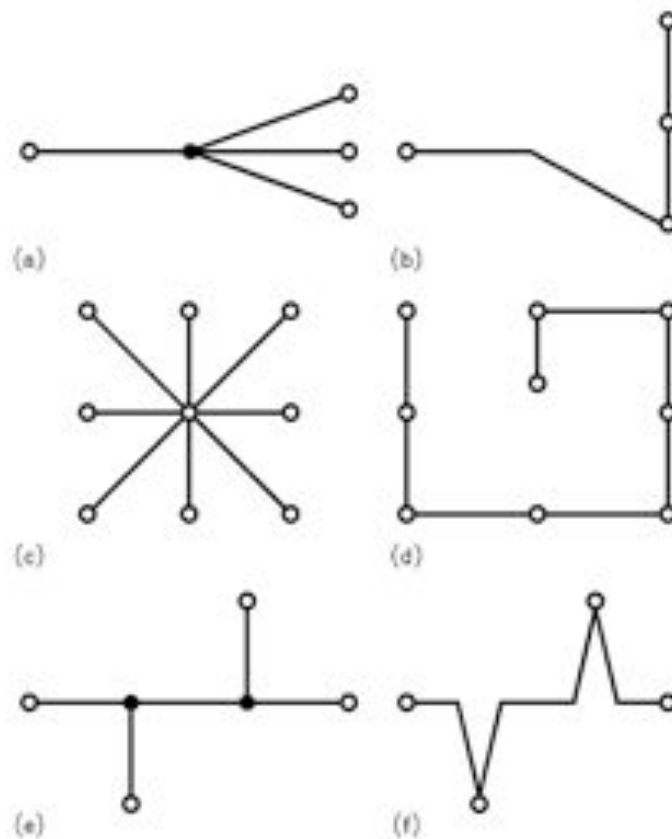

Figure 2.27: Typical RS485 network connections (Topologies).

The optimal configuration for the RS-485 bus is the daisy-chain connection from node 1 to node 2 to node 3 to node n. The bus must form a single continuous path, and the nodes in the middle of the bus must NOT be at the ends of long branches, spokes, or stubs. Figure 2.27a, 2.27c, and 2.27e illustrate three common but **improper** bus configurations. Figure 2.27b, 2.27d, and 2.27f show equivalent daisy-chained configurations.

Connecting a node to the cable creates a ‘stub’. Minimizing the stub length minimizes transmission-line problems. For standard transceivers, stubs should be shorter than 6 inches. A better rule is to make the stubs as short as possible. A “star” configuration (Figure 2.27c) usually does not provide a clean signaling environment even if the cable runs are all of equal length. The star configuration also presents a termination problem, because terminating every endpoint would overload the driver. Terminating only two endpoints solves the loading problem but creates transmission-line problems at the un-terminated ends. A true daisy-chain connection avoids all these problems.

The characteristic impedance of the cable should be 100Ω to 120Ω . A common misconception is that the cable’s impedance must be exactly 120Ω , but 100Ω works equally well in most cases. Note that a cable impedance of 120Ω presents a lighter load, which can be helpful if the cable runs are extremely long.

Both ends of the main cable require termination. Another common mistake is to switch the terminating resistor at each MTS amplifier—a practice that causes trouble on buses

that have four or more amplifier. The active driver sees the four termination resistors in parallel, a condition that excessively loads the driver. If each of the four nodes connects a 100Ω termination resistor across the bus, the active driver sees a load of 25Ω instead of the intended 50Ω. The problem becomes substantially worse with 32 nodes. Only TWO MTS amplifiers should have the termination resistor switched in and those should be at either end of the daisy chain.

Another major issue in creating reliable RS-485 networks is proper grounding. Although the potential difference between the data-pair conductors determines the signal without officially involving ground, the bus needs a ground wire to provide a return path for induced common-mode noise and currents, such as the receiver's input current. A typical mistake is to connect two MTS amplifiers with only a two wire twisted connection. If you do this, the system may radiate high levels of EMI, because the common-mode return current finds its way back to the source, regardless of where the loop takes it. An intentional ground provides a low-impedance path in a known location, thus reducing emissions.

Note: Using any form of earth ground is a poor choice for referencing RS485 signal grounds on MTS amplifiers. The best method for controlling VGPD is to simply run a third wire (preferably the shield of a twisted pair cable) for the purpose of referencing local signal grounds. A shield both prevents the coupling of external noise to the bus and limits emissions from the bus.

MTS recommends the use of cable designed for use with RS485 networks, such as Belden 9841, or equivalent.

2.9.2 MTS amplifier pinout

The MTS amplifier uses a 3.5mm mini-Euroblock connection. The termination is shown in Figure 2.28



Figure 2.28: RS485 pinout

2.9.3 V-Bus Monitor Software

MTS has a simple Monitoring application for the serial control port. The current version is VBUSMON 5_0_63 and is available on the MTS website under the downloads section.

VBUSMON is a Windows XP/Vista application that can also be used on MAC OS X using either Bootcamp and Windows XP/Vista, or a virtual machine (VMWare or Parallels) and Windows XP/Vista.

VBUSMON is intended to provide the user with a straightforward method of looking into the RS485 serial port and inspecting and/or manipulating the internal control &

monitoring capability of the amplifier. Its value is primarily as a site testing and commissioning tool for systems integrators.

VBUSMON is a simple “Lua” application that uses the same command set described in section 2.7 above.

Installing VBUSMON is simple... just double click on the VBUSMON_5_0_63.exe and follow the instructions.

VBUSMON connects to the amplifier using the serial port of the host PC or laptop. In the case of a desktop PC, the default options of COM1 or COM2 communicates via the PC’s RS232 serial ‘COMPORT’. As COM1 or COM2 is RS232 and the MTS amplifiers communicates over RS485 an RS232 to RS485 adapter interface is needed. MTS recommends the B&B model 485D9TB (<http://www.bb-elec.com/>).

As most laptops no longer have an RS232 COMPORT, it is likely that a USB to RS232 adapter will be used (note: this still needs the RS232 to RS485 interface). In this situation, the standard COM1 or COM2 options may not be applicable and the following procedure is needed:

- Insert the USB to serial adapter and follow the product instructions to load the driver (usually plug and play).
- Click on the Windows “START” menu and right click on “My Computer”.
- Select the Hardware and Device manager tabs. There should be a section marked “Ports”. Click on the “+” sign to open the tabview and it should show the USB to serial adapter. In the example in Figure 2.29 (below) it is shown as “Prolific USB Serial Comm Port (COM3)”.

This means that the adapter is using COM3 to communicate out of the laptop.

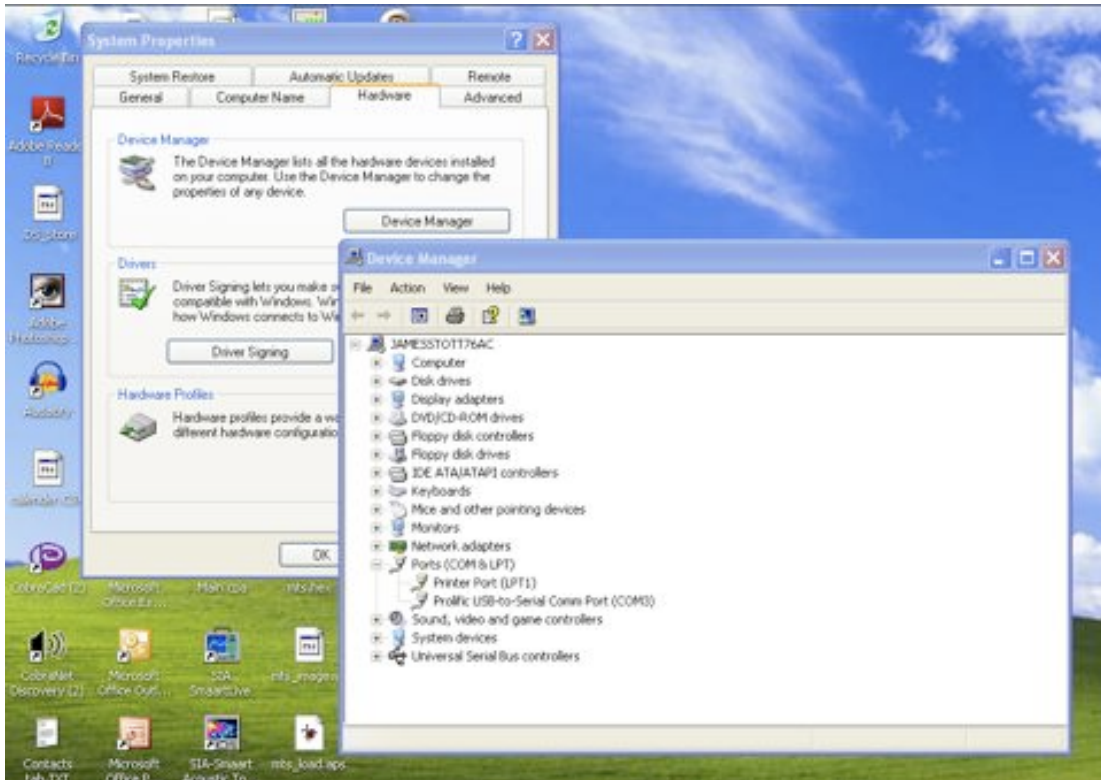

Figure 2.29: Locating the COMPORT used by the USB-Serial adapter.

- The VBUSMON software needs to be set up to communicate through the COM3 port rather than the COM1 or COM2 port. This is done by creating a shortcut on the desktop and right clicking on the shortcut to open its properties (see Figure 2.30).



Figure 2.30: Desktop shortcut and properties menu

In the properties menu (Figure 2.31 below), go to the “Target” line and change the “... VBusMon\Bin\vbusermon.exe” COM2 to COM3 and press “Apply”. This will change the default COMPORT used by the VBUSMON application to COM3. Then press “OK” and close the properties menu.

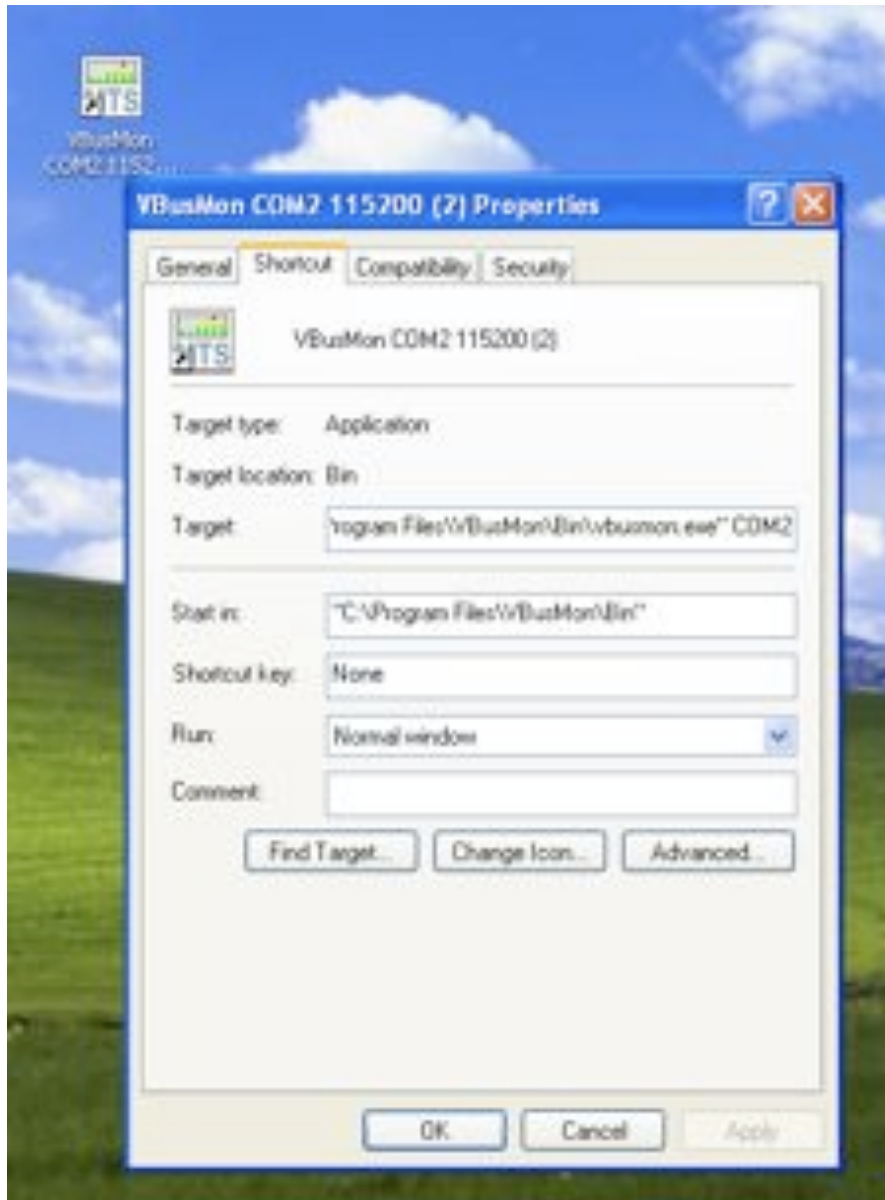

Figure 2.31: Changing the COMPORT target to COM3

Double clicking on the modified VBUSMON shortcut will enable the application to communicate to the amplifier using COM3.

Once the software is loaded, then double click the shortcut to open the application. If an error message appears (see Figure 2.32 (below) it means that the USB to Serial adapter cannot be found at COM3 and is either disconnected or associated with a different COMPORT.

If the USB to serial adapter is setup correctly, then the application will open as shown in Figure 2.33 below.

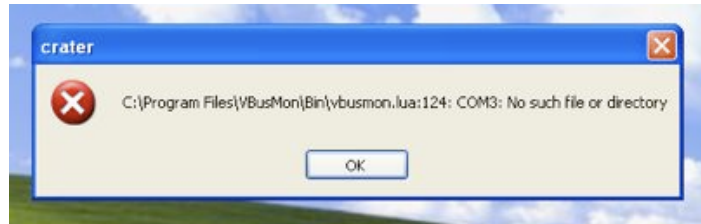

Figure 2.32: COMPORT error



Figure 2.33: VBUSMON application opening page.

The VBUSMON application will allow the manual transmission of the V-BUS command set described in section 2.7 above. The settings are:

- UA (Unit address): This is the RS485 network address set by the DIP switches on the back of the amplifier.
- SA (Sending address): This is the RS485 address of the host computer and should always be set to 41. NOTE: When using VBUSMON with the Cobranet RS485 port, the SA MUST be more than 41 (eg 42), as the 41 address is reserved for the internal amplifier RS485 port.
- ACK and NAK: Allows the user to manually send the acknowledgement and negative acknowledgement responses after receiving data from the amplifier
- Select: Allows the user to send data using the Select (SEL) command.
- CMD: One of the 80-87 commands described in section 2.7.
- Poll: Initiates a command.

The Monitor pull down tab will show 2 options: Log and Signals. These are described as follows:-

- The Signals tab will show the display in Figure 2.34 below. Note: If “Timeout” is shown in the bottom right corner, then the RS485 bus is not connected to the amplifier. If connection is successful, then “OK” will show.

The rest of the lower right information section will show connection details, product model details, 70 or 100volt line selection, etc.



Figure 2.34: VBUSMON Signals page.

Figure 2.35 (below) shows the signals page connected to a COM3004 amplifier, ie 300watts, 70volt setting, 2 amplifier modules (each module is 2 channels, so 4 channels total). The DIP switch address is 60 and the software is communicating on COM1

As the amplifier is only 2 modules/4 channels, the temperature for modules 3 and 4 are zero and the controls for channels 5...8 are set at -51.75dB.

The remainder of the signals page are a graphical representation of the data from the RS485 port. Notes...

- The Attenuation controls are only set when released. The action is not continuous.
- The Attenuation control varies from +12 to -72dB. The +12db allows -8dBu consumer equipment such as CD players to connect directly to the amplifier.
- “Mute” is not setting the gain control to zero, but disconnects the output relay
- “SMPS” switches off the class D output stages (so no power is consumed) and disconnects all output relays.
- “PRE” is the input stage to the VCA control and is a +24dBu clip signal
- “PST” is the output stage ‘post’ VCA and at the input stage of the power amplifier. The clip point is set to the clip point of the amplifier, ie +8dBu.
- “VOL is the real time output voltage of the amplifier.

- “CUR” is the real time output current of the amplifier. The output current may appear to be reading low compared to the output voltage, but the scale is set to the worst case 2 ohm (AV-SI series) current limit. The actual current drawn will depend on the load impedance.

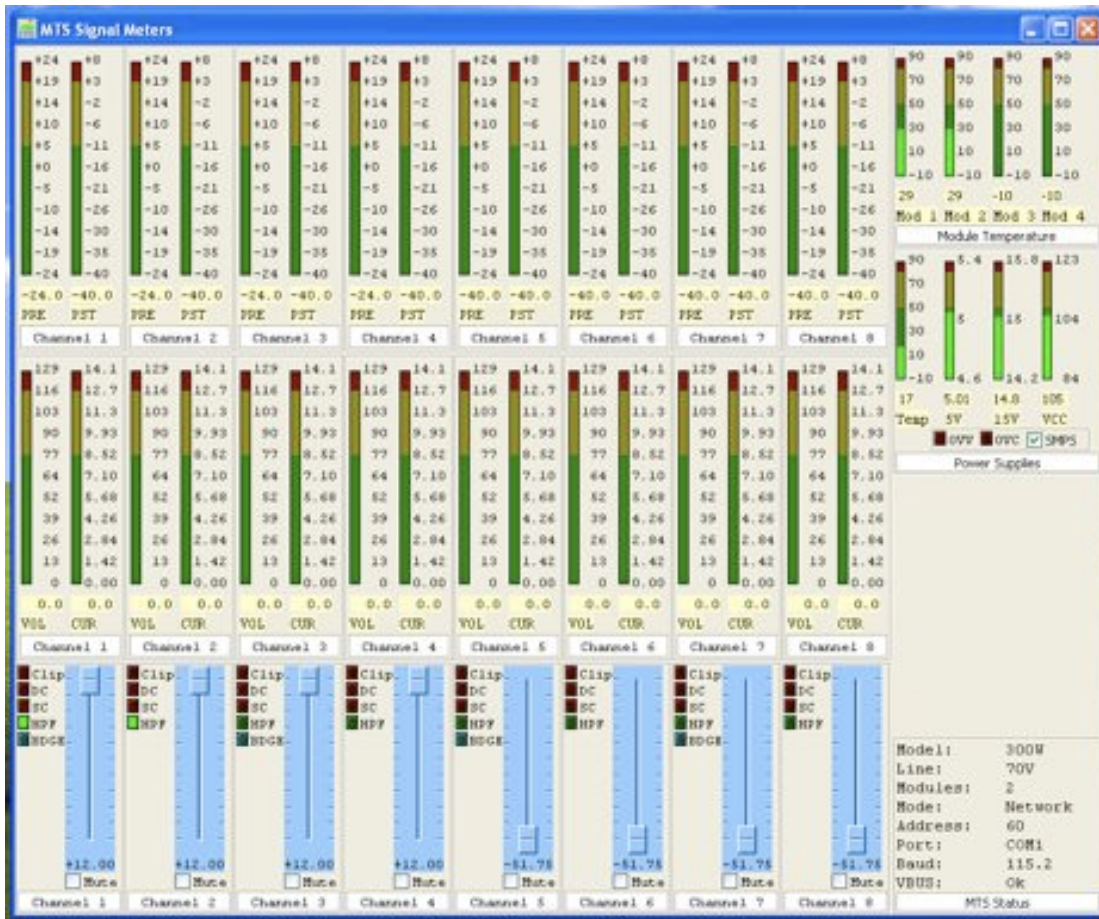

Figure 2.35: Signals page connected to an amplifier

- The Log tab allows the user to monitor the data sent to and from the MTS amplifier, see Figure 2.36 below.

When any of the buttons are pressed in the VBUSMON page, the RS485 instruction is shown in the Log page. If “hex in” and “Hex out” checkboxes are selected, then the actual hexadecimal code is shown.

There are also options for viewing the data as ASCII or Hexadecimal.

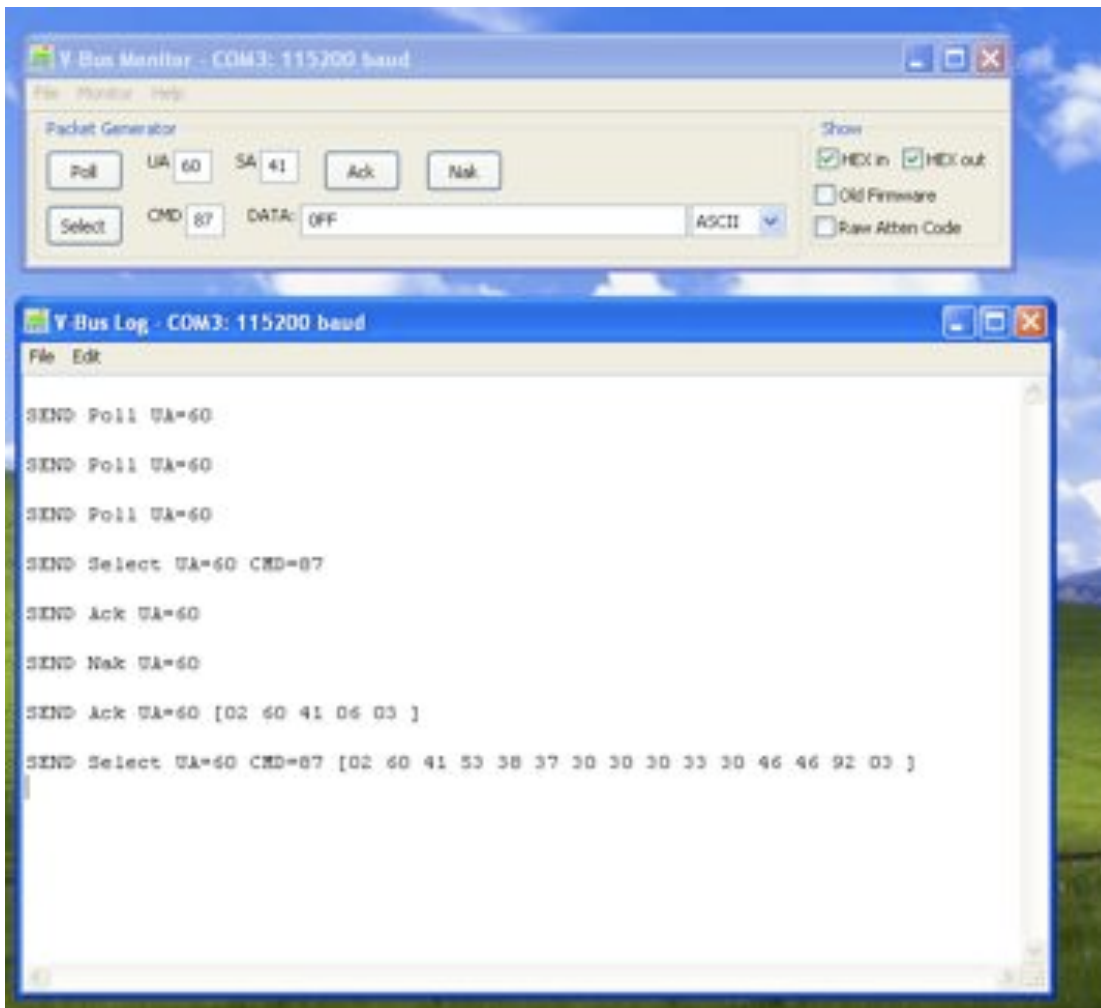

Figure 2.36: VBUSMON Log monitor tab page.

Figure 2.37 below shows the VBUSMON page when connected to an amplifier. A POLL instruction returns a full dataset. As the amplifier is a COM3004, only 4 channels (2 modules) of data are generated.

For ease of debugging systems, the Log page also shows the hex values of the data against the parameters listed.

For example, VCCamp shows 135. This is an 8 bit value, ie 135 out of a maximum of 256. Section 2.2.4 (above) shows that for a 70volt model, the value 135 should be multiplied by 153.6mV to get 20.736volts. Adding the offset of 84volts gives a total of 104.736 volts.

The Signals page shows a value of 105volts for the COM3004. As the COM is a 70/100volt amplifier in 70volt mode, the RMS output of the amplifier will be 70volts, or 100volts peak (70 x 1.414). Adding in the drop across the output devices would require a rail voltage of around 105volts.

```
SEND Poll UA=60 [02 60 41 50 03 ]
02 41 60 44 38 37 30 30 34
41 30 43 30 39 35 38 37 38 34 34 32 36 41 31 30
31 33 30 30 34 37 32 30 34 37 32 30 30 30 30 44
31 33 34 30 30 35 32 46 46 46 46 43 30 33 30 30
34 37 32 30 34 37 32 30 30 30 30 37 32 42 38 30
30 35 32 46 46 46 46 43 30 30 30 A4 03
DAT dat=41 acc=60 SCC Ok
cmd=07, 74 data chars
vcc5 144
vcc15 133
vccamp 135
model 68
pict 98
mpot 24
fault 0
control 1
status 3
module 1 2
sig1pe 64 64
sig1po 39 39
sig2pe 64 64
sig2po 39 39
ocur1 0 0
ocur2 0 0
ovol1 29 39
ovol2 67 139
temp 37 37
att1 255 255
att2 255 255
fault 12 12
status 3 0
control 0 0
```

Note: The network amplifier (see section 3.0) still has the RS485 port available, but the data stream is sent to the network card. It is possible to have the data stream factory set to the RS485 port, but the amplifier control and monitoring data will then be unavailable over the network, ie ONLY available via the RS485 port.

3 Network Amplifiers

There are two product lines of MTS multichannel network amplifiers: The SI series (LoZ 4/8ohm output impedance) and COM series (HiZ 70/100volt output drive).

The SI and COM series amplifiers are an upgraded version of the AV-S and PAG-S series specifications (respectively), where the following capability has been added:-

- Cobranet Port: The Cobranet port uses the Cirrus Logic CS181xxx/CS496xxx chipset (similar to the commonly used CM2 card). This allows for up to 16 audio input channels from the network, up to 16 audio output channels to the network, 8 local analog input channels from the amplifier (that can be bridged on to the network) and 8 local analog output channels from the network (and/or the analog inputs) to the amplifier.

In addition to audio transport, the Cobranet port provides control and monitoring capability via SNMP. MTS has a separately purchasable option for an OEM version of Stardraw control with embedded MTS SNMP drivers for custom GUI rendering.

The SNMP controls include all the standard Cobranet OID's, the Cirrus DSP extensions and all MTS manufacturer extensions for the internal amplifier control and monitoring capability.

See Cirrus Logic's UM23 users manual for full details of the chipset and PM25 programmers manual for full details of the SNMP controls...

<http://www.cobranet.info/en/products>

- Ethernet port: The Ethernet port provides control & monitoring capability of all amplifier, DSP and Cobranet parameters using a simple TELNET based protocol.

In smaller systems, it is likely that the Cobranet port will be used for both audio transport and control & monitoring. For larger systems, where the audio transport is on a separate VLAN (to control bandwidth), the TELNET port will provide access to separate control & monitoring port that can be added to the general AV/BMS system.

Note: The control & monitoring is either/or, ie TELNET or SNMP, but not both simultaneously.

- Additional RS485 Port: The additional RS485 port provides a serial connection, so that 3rd party serial data can be bridged on to the Cobranet network for communications between Cobranet nodes/MTS amplifiers.

Note: It is assumed that the SI and COM series amplifiers will provide either SNMP or TELNET control of the internal amplifier control & monitoring capability. However, if the amplifier RS485 control port is required, then a

factory accessible internal switch needs to be set to the lower position (upper position connects the amplifier control and monitoring to the Cobranet and Ethernet ports).

Note: When using VBUSMON with the Cobranet RS485 port, the SA MUST be more than 41 (eg 42), as the 41 address is reserved for the internal amplifier RS485 port.

- DSP: The DSP is based on the CS496122 chipset and provides >100MIPS of processing power.

3.1 Cobranet

The standard Cobranet tools, including Cobranet Discovery (CNDISCO) and CobraCAD are available for use with the MTS Cobranet enabled amplifiers. These tools are available as a free download from the Cirrus Logic Website.

MTS uses a custom implementation of the Cobranet firmware and the latest MTS_x_xx_xx.bin file (MTS_2_11_6.bin as of February 2008) is available as a download from the MTS website. Do NOT use the Cirrus Logic binary file, otherwise the DSP and Amplifier control and monitoring extensions will be missing.

3.2 SNMP

The Cobranet port also provides control and monitoring of all parameters using SNMP. There are three sets of controls, Cobranet protocol, DSP parameters and Amplifier parameters.

Notes: All Cobranet and RS485 settings need up to 1 minute to establish persistence, as they are stored in the cobranet flash. If the amplifier power is cycled before the settings are stored to flash, then the settings will be lost.

3.2.1 Cobranet OID's

These are detailed in the Cirrus Logic programmers manual (current version PM25) and covered in the standard Cirrus CIRRUSLOGIC-CNDSP-MIB file.

3.2.2 DSP extensions

See section 6.5 of the PM25 programmers manual for full details. The DSP extensions are based on the xml output file generated by the Cirrus Logic DSP Conductor software. The DSP extensions use a block of memory addresses in the HMI that are made available through SNMP OID's. The xml output provides a method of explaining what DSP controls are associated with which HMI memory addresses.

The xml code is typically as follows (example from Cirrus Applications Note)...

```
1. <?xml version="1.0" standalone="yes" ?>
```

```

2. <dsp_conductor_control_map>
3. <info>
4. <signature value="3239014490" />
5. <project_name value="untitled1" />
6. <date_time value=" 11/02/2005 04:33 PM" />
7. </info>
8. <devices>
9. <device title="Sine" type="generator_sine_wave" path="Sine" id="1" >
10. <coefficient name="gain" offset="2" mode="RW" signed="1" fract_bits="31" />
11. <coefficient name="omega" offset="1" mode="RW" signed="1" fract_bits="31" />
12. <coefficient name="ramp" offset="0" mode="RW" signed="1" fract_bits="31" />
13. </device>
14. <device title="Presence" type="detector_signal_presence" path="Presence" id="2">
15. <coefficient name="hold_time" offset="5" mode="RW" signed="1" fract_bits="0" />
16. <coefficient name="infinite_hold" offset="4" mode="RW" signed="1" fract_bits="0" />
17. <coefficient name="presence" offset="1" mode="RO" signed="1" fract_bits="0" />
18. <coefficient name="threshold" offset="3" mode="RW" signed="1" fract_bits="31" />
19. </device>
20. </devices>
21. </dsp_conductor_control_map>

```

- Line 1 is standard XML boilerplate.
- Line 2 is the root element of the document, called dsp_conductor_control_map. This element ends on line 21 in the example.
- Line 3 is the beginning of the info element that provides general information about the configuration. This element ends on line 7 in the example. There will be exactly one info element in the file.
- Line 4 is the signature element. This element contains a single attribute called value that contains a 32-bit unsigned long integer that is the signature of the configuration. The signature uniquely identifies the layout and the data types of the coefficients in the configuration. The signature value may be read from the first location in the read-only parameter buffer. When you establish communications with the CS4961xx you should read the signature value and confirm that it matches the signature from the configuration XML before reading or writing any coefficients. If the signatures do not match, any values that you read will be meaningless and any values that you write will have unpredictable results.
- Line 5 is the project_name element that contains a single attribute called value that contains the name of the configuration.
- Line 6 is the date_time element that contains a single attribute called value that contains a string describing the date and time that the configuration was compiled.
- Line 8 is the beginning of the devices element. This element contains a series of device elements. There will be exactly one devices element in the file.
- Line 9 is the beginning of the first of many device elements. There will be one device element for each DSP Conductor processing Element in the configuration. The device element contains four attributes.
 - The title attribute contains the text on the face of the Element.
 - The type attribute contains the internal type name of the device, which is more technical than the title. This is the same as the <primitive name> described in Section 3.
 - The path attribute normally looks exactly like the title but, in the case

where the Element resides inside a hierarchical block, path will contain the title of the block followed by a forward slash and then the title of the Element. Since Elements can be nested inside Hierarchical blocks inside other Hierarchical blocks to an arbitrary depth, the path is really the concatenation of the titles of all of the blocks, from the outermost block to the innermost block followed by the title of the Element itself, all separated by forward slashes.

- The id attribute contains a unique integer identifying the instance of the Element in the configuration, this is the same as the <primitive ruid>
- Finally, the device element contains a series of coefficient elements.
- Line 10 is the first of many coefficient elements. There is one coefficient element for each parameter that can be read or written to control the DSP configuration. Each coefficient element contains five attributes.
 - The name attribute contains the name of the parameter. This is the same as <parameter name>
 - The offset attribute is the word offset of the parameter.
 - The mode attribute is either 'RW' signifying read-write or 'RO' signifying read-only.
 - The signed attribute is either 1, indicating the parameter is signed or 0, indicating the parameter is unsigned.
 - The fract_bits attribute indicates the number of fractional bits in the parameter. Note that the minimum value of offset among all 'RW' parameters is 0, but the minimum value of offset among all "RO" parameters is 1. This is because offset 0 in the 'RO' space contains the signature as described above.

Parameter Values: All DSP Conductor parameters are 32-bit values. While the sign (sg) and fraction bits (fb) attributes give some indication of how the DSP might interpret the values, in the end, it is the specifics of the DSP implementation that determine exactly how values are interpreted. The way values are interpreted can be discerned by examining the Crunch Functions section in the element's implementation XML file. For details on the implementation XML file refer to Cirrus application note AN277, "Creating DSP Conductor Primitives".

Forming SNMP OIDs: All SNMP variables are referenced by the object identifier (OID). An OID is a dot-separated string of integers enumerating the path from the root of the SNMP management information base (MIB) to the variable. Firmware supporting DSP Conductor features a dspExtensions SNMP extension agent rooted at...

```
iso(1).org(3).dod(6).internet(1).private(4).enterprises(1).peakAudio(2680).cobraNet(1).dspExtensions(4).
```

DSP Conductor parameters under this extension are separated into two tables of 32-bit integers. The first table, rooted at...

```
dspExtensions(4).control(2).controlRWTable(2)
```

...holds read-only parameters. The second table, rooted at...

```
dspExtensions(4).control(2).controlROTable(4)
```

...holds read/write parameters. Note that access to SNMP tables is achieved using 1-based indices. The word offsets specified in the configuration header file are 0 based.

To construct an OID for a read/write variable, append the parameter's word offset (wo) plus one to the OID for the controlRWTable values:

```
iso(1).org(3).dod(6).internet(1).private(4).enterprises(1).peakAudio(2680).cobraNet(1).dspExtensions(4).control(2).controlRWTable(2).controlRWEntry(1).controlRWValue(2)
```

For example, the OID for a read/write parameter with word offset 5 is
1.3.6.1.4.1.2680.1.4.2.2.1.2.6

To construct an OID for a read-only variable, append the parameter's word offset (wo) plus one to the OID for the controlROTable values:

```
iso(1).org(3).dod(6).internet(1).private(4).enterprises(1).peakAudio(2680).cobraNet(1).dspExtensions(4).control(2).controlROTable(4).controlROEntry(1).controlROValue(2).
```

For example, the OID for a read-only parameter with word offset 13 is
1.3.6.1.4.1.2680.1.4.2.4.1.2.14

The MTS amplifiers also have optional DSP personalities for different applications. A full set of DSP extensions for the MTS SI and COM series amplifiers are available from the MTS website.

3.2.3 MTS amplifier extensions

The CobraNet ethernet port access to amplifier chassis parameters are serviced by the CobraNet module on a mutually exclusive basis with the Ethernet port (i.e. global data will not be written and attn and control cmds will not be serviced via SNMP when TELNET is in use).

The Global Read Command is mapped into the stdUserString OIDs as follows (NOTE: sometimes the SNMP OIDs aren't recognized by the CobraNet processor unless the correct OID is followed by a ".0"):-

1.3.6.1.4.1.2680.1.3.3.2.1.2.1

Module response bytes (MODULEL, MODULEH). Amplifier host data (VCC5L through STATUSM bytes). Amplifier Module 1 data if present (SIG1PEL through CONTROL1 bytes)

1.3.6.1.4.1.2680.1.3.3.2.1.2.2:

Note due to the 4 byte data set, the last 2 bytes of this string are always set to 0x00 and should be discarded.

Amplifier Modules 2,3 data if present (SIGnPEL through CONTROLn bytes)

1.3.6.1.4.1.2680.1.3.3.2.1.2.3

Amplifier Module 4 data if present, (SIGnPEL through CONTROLn bytes)

The Attenuation and Control Write Commands will be entered as a stdUserString at OID

1.3.6.1.4.1.2680.1.3.3.2.1.2.4

Attenuation Write Command:

- Enter command with data formatted as described in V-Bus specifications (section 2. above) minus the STX, UA, SA, SEL, BCC and ETX fields.

CMD (1 byte)	SIZE (2 bytes)	DATA (up to 17 bytes)
80	0022	0F65DD4707DBDD07DB

Example: Attenuation Write Command

- Set flag to indicate that a command is entered. Write a 1 to stdUserInteger OID 1.3.6.1.4.1.2680.1.3.3.3.1.2.5. NOTE: Do not enter another command until this flag is set back to zero.

Control Write Command:

- Enter command with data formatted as described in V-Bus specifications (section 2. above) minus the STX, UA, SA, SEL, BCC and ETX fields.

CMD (1 byte)	SIZE (2 bytes)	DATA (up to 17 bytes)
81	0003	0A0

Example Control Write Command

- Set flag to indicate that a command is entered. Write a 1 to stdUserInteger OID 1.3.6.1.4.1.2680.1.3.3.3.1.2.5. NOTE: Do not enter another command until this flag is set back to zero.

Notes:

1. In V-BUS the values are entered in ASCII. In the SNMP OID's the values are entered in HEX, so instead of CMD = 2 bytes of ASCII, SIZE = 4 bytes of ASCII and DATA = 34 bytes, CMD = 1 byte of HEX, SIZE = 2 bytes of HEX and DATA = up to 17 bytes of HEX

2. IMPORTANT: As the Control data can have ½ bytes (ie nibbles), the SIZE is measured in nibbles and NOT bytes. As an example, to put the amplifier into standby, the string would be 81 0003 000, ie 3 nibbles of 000 Data. To take it back out of standby would be 81 0003 001.

3. Setting the Bridge bit to 1 in the Cobranet Serial bridge OID will render the local/remote/bridge settings and master/slave settings from the GUI or TELNET port invalid.

3.3 Ethernet

3.3.1 TELNET

The Ethernet port uses the TELNET protocol for communication, see Figure 3.1.

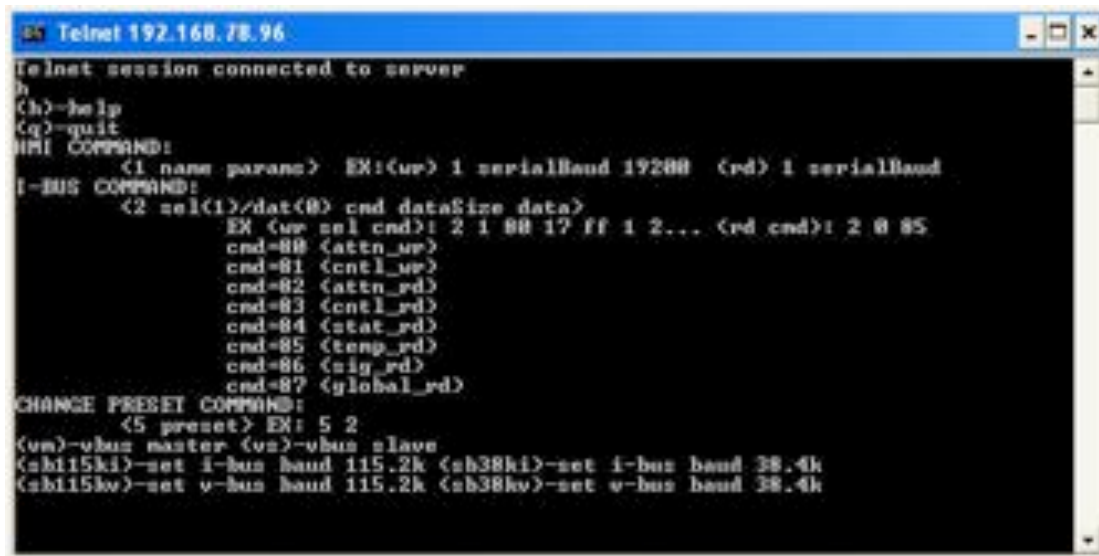

```
Telnet 192.168.78.96
Telnet session connected to server
h
(h)-help
(q)-quit
HMI COMMAND:
  <1 name param> EX:(uv) 1 serialBaud 19200 (rd) 1 serialBaud
I-BUS COMMAND:
  <2 sel(1)/dat(0) cmd dataSize data>
  EX (uv sel cmd): 2 1 80 17 ff 1 2... (rd cmd): 2 0 85
  cmd=80 (attn_uv)
  cmd=81 (cntl_uv)
  cmd=82 (attn_rd)
  cmd=83 (cntl_rd)
  cmd=84 (stat_rd)
  cmd=85 (temp_rd)
  cmd=86 (sig_rd)
  cmd=87 (global_rd)
CHANGE PRESET COMMAND:
  <5 preset> EX: 5 2
(vm)-vbus master (vs)-vbus slave
(sb115ki)-set i-bus baud 115.2k (sb38ki)-set i-bus baud 38.4k
(sb115kv)-set v-bus baud 115.2k (sb38kv)-set v-bus baud 38.4k
```

Figure 3.1: Screen shot of TELNET session and instructions.

The instruction set is as follows:-

- h – help (displays menu)
- q – quit
- 1 <Name> < Parameters> - (hmi command where Name is Name from CobraNet Programmer's Reference PM25)
- 2 <cmd type> <cmd> <data size> <data> - (Amplifier cmd as specified in section 2.7 above where...
 - cmd type is 1 for SEL and 0 for DAT
 - cmd is 80 through 87, etc...)
- 5 <preset> - (change preset)
- vm – set unit as V-Bus master
- vs – set unit as V-Bus slave
- sb115ki – set I-Bus baud rate to 115.2k
- sb38ki – set I-Bus baud rate to 38.4k
- sb115kv – set V-Bus baud rate to 115.2k
- sb38kv – set V-Bus baud rate to 38.4k

3.3.2 Ethernet GUI

There is a simple test GUI available for setting up the Cobranet port parameters, the amplifier parameters and controlling the COM series internal amplifier DSP. This can be downloaded from the MTS website.

To use the GUI, the host PC or laptop must be set to the default IP subnet in order to talk to the amplifier. Figure 3.2 below shows the method of setting up a Windows computer.

First, go to Control Panel and then open "Network connections".

Then, click on the General tab and open "Properties".

Select "Internet Protocol (TCP/IP)" and click on properties.

Finally, change the selection from "Obtain an IP address automatically" to "Use the following IP address" and set as follows:-

- IP address: 192.168.192.50
- Subnet mask: 255.255.255.0

It can be any IP address in the range 192.168.192.2 to 192.168.192.99. Note that the amplifier default address shipped from the factory is 192.168.192.100.

Once the IP address and subnet mask has been set then open the GUI application.

After finishing using the GUI, return to the Control Panel and reset the selection back to "Obtain an IP address automatically".

If an intelligent or managed switch is in use, then the switch address will need to be set to the same subnet, usually 192.168.192.1 or 192.168.192.254.

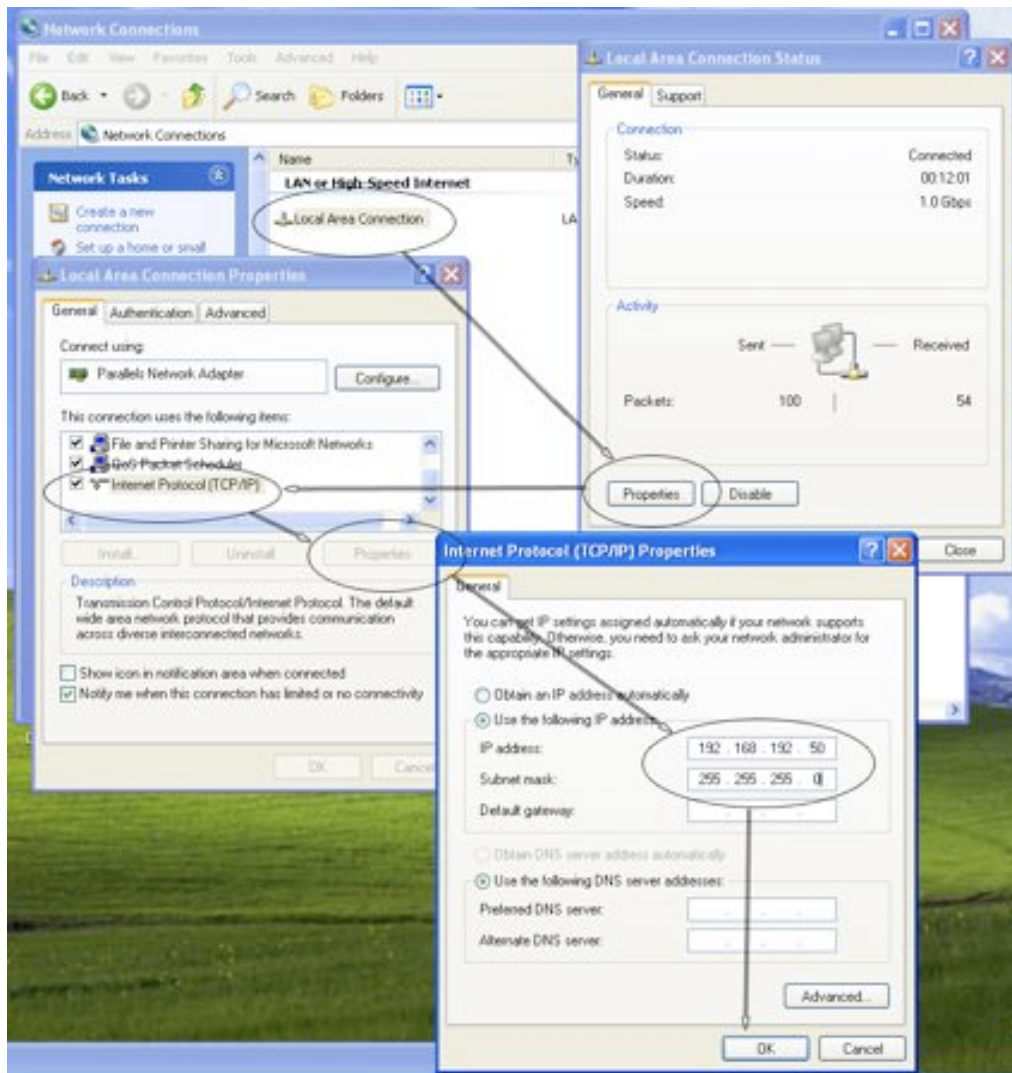

Figure 3.2: Setting up the IP address and subnet mask.

3.3.2.1 GUI default page

The GUI application default page is shown below in Figure 3.3.

The default page will show 192.168.192.100, as this is the factory IP address set in each amplifier. If this is a new amplifier, then simply press "Connect". If the amplifier has been set with a different IP address then use the amplifier display to confirm the IP address-see Section 4.0 below.

Note: Each amplifier will attempt to obtain an IP address by DHCP on power up. This process lasts about 1 minute. Until the DHCP period is over, it will not be possible to connect to the amplifier using the GUI. If the amplifier is unsuccessful in obtaining an IP address using DHCP, then it will use the stored default address.



Figure 3.3: GUI opening page

NOTE: many pages, or sections of pages, have an “UPDATE” button. If changes are made through SNMP, RS485 or TELNET, rather than the GUI, these changes will only be reflected in the GUI after pressing UPDATE. Otherwise, the GUI would have to continuously poll every setting and the HMI would have little processing time left over.

3.3.2.2 System settings

Selecting the “System” tab will open the page shown in Figure 3.4 below. The settings are changed as follows:-

- Ethernet IP address: This can be changed from the default address to any address. Enter the new address and press “Set”. Note: once the IP address is changed, the user will need to wait approximately 20 seconds for the application to reconnect, or they can restart the application and enter the new address.
- Cobranet IP address: As Cobranet is layer 2, it does not need an IP address to pass audio. However, for programming via SNMP the default Cobranet address of 0.0.0.0 can be changed. The IP address set using the GUI is persistent.
- The Cobranet firmware revision is for information only. There is no setting. New firmware should be loaded using Cobranet Discovery (CNDISCO).
- The indicators show the module temperature, SMPS temperature and SMPS supply rails. In the example below, the amplifier is a COM3004 and only has 2 modules.

- The RS485 port settings refer to the port connected to the network card and not the amplifier RS485 port described in section 2.9 above. The parameters are set as follows:
 - The RS485 bridge status allows the user to switch the RS485 port between local/remote amplifier control & monitoring or serial bridging.
 - The RS485 address refers to the address used by the RS485 port to communicate to external devices. It is the same as set by the DIP switches.
 - The RS485 Master/Slave switch allows the Amplifier to be slaved to a host processor or act as the Master controller for the MTS wall panels or a remote MTS amplifier (see a more detailed explanation below).
 - The remote MAC address refers to the serial bridging channel settings described in the Cirrus Logic PM25 document.

Note: RS485 settings as follows...

- Local = Local RS485 control and monitoring of all amplifier parameters via the Cobranet RS485 port (ie serial bridging is off). The Master/Slave toggle then determines whether the amplifier is slaved to a separate PC/Processor (eg VBUSMON) or acting as the master to communicate with wall plates (TBA).
- Bridge = Serial bridging, where the cobranet RS485 port is simply a multidrop bidirectional serial communications channel. The data at the Cobranet RS485 port is not used by the local amplifier, but communicated to a remote device(s) on the network. This is the standard Cirrus setup. Master/Slave also has no effect in this situation.
- Remote = Remote control via serial bridging, ie a serial port on a remote Cobranet interface can control and monitor the local amplifier.

In summary, for local control of the amplifier via the RS485 port, set the amplifier to local and slave. For remote control of the amplifier over serial bridging, set the amplifier to remote and slave. For remote control of a remote amplifier via the RS485 port, set to bridge and master. For pure serial bridging, set both amplifiers to bridge and the master/slave setting is irrelevant.

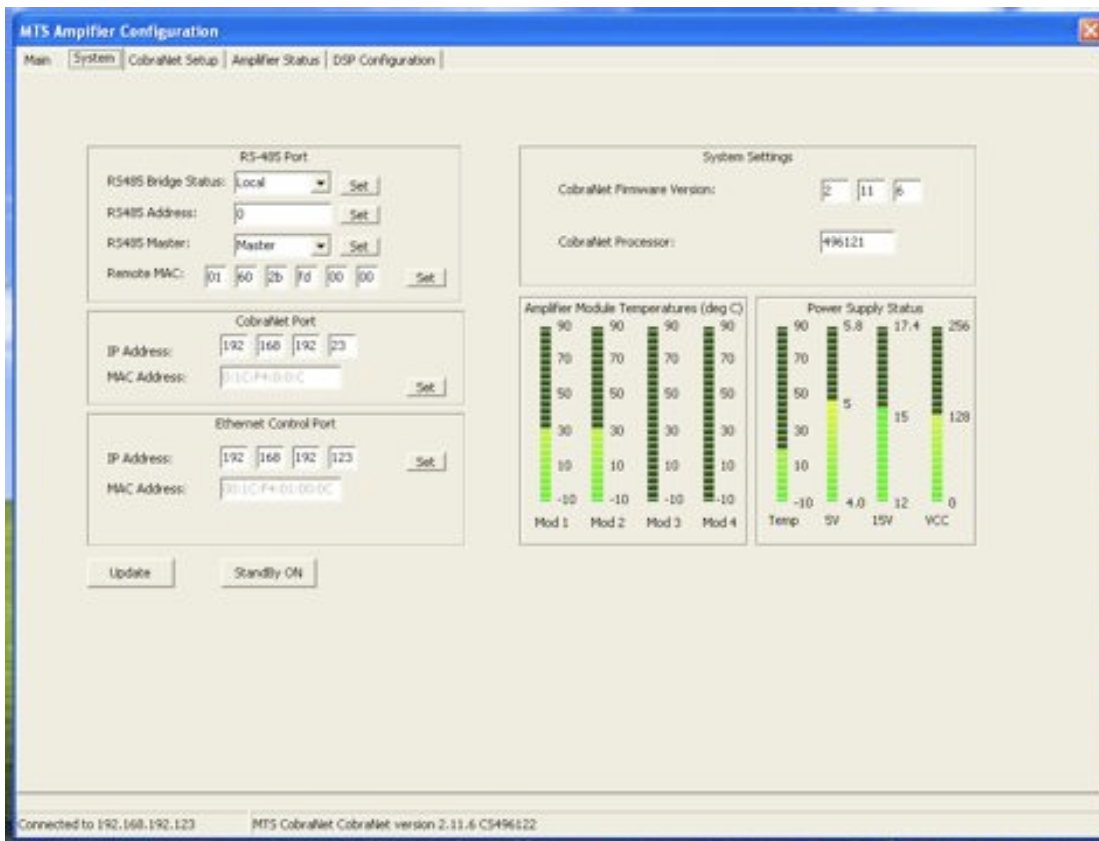

Figure 3.4: System settings page.

Notes:

- All RS485 settings need up to 1 minute to establish persistence, as they are stored in the cobranet flash. If the amplifier power is cycled before the settings are stored to flash, then the settings will be lost.
- The RS485/CobraNet DIP switch on the rear of the amplifier should be set to CobraNet. If it is set to RS485, then the RS485 address on the DIP switches must match the RS485 address used in the GUI/VFD display and the I-bus baud rate and master/slave setting must match that used in the GUI/VFD display.

3.3.2.3 CobraNet settings

The CobraNet settings page is shown below in Figure 3.5. Note that one of the key features of the MTS Multichannel amplifier is the ability to set up to 4 CobraNet audio transmitters and 8 CobraNet receivers. In addition, MTS has provided the ability to set each bundle subchannel configuration.

Note: The settings are persistent, ie they will be stored into flash memory in the amplifier, BUT, the store process can take up to one minute, depending on the degree of other processing taking place. It is safer to allow at least a minute after making a setting change and before cycling power.

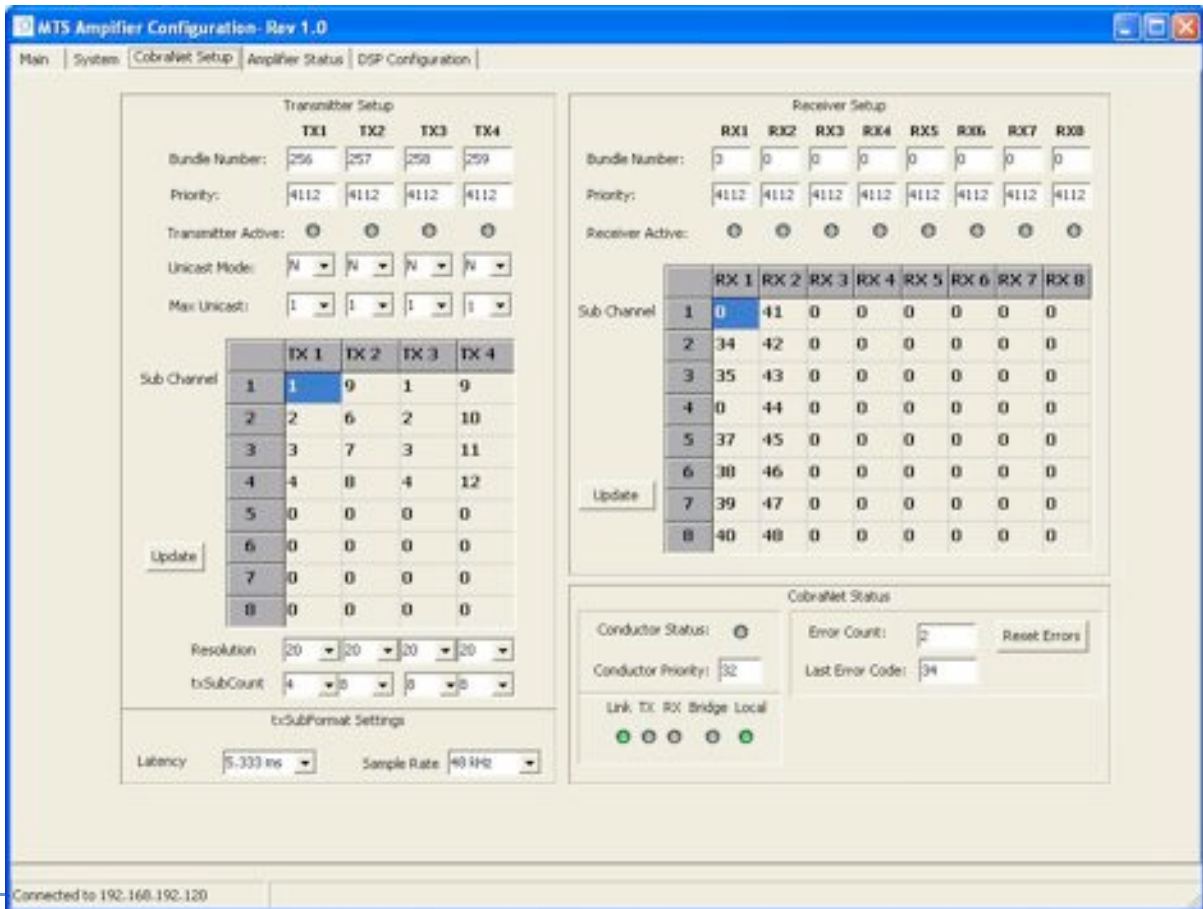

Figure 3.5: Cobranet settings page

The settings are:-

- Transmitter setup: This section covers the Cobranet transmitters. The CS496xxx chipset allows for up to 4 transmitters, each of up to 8 channels, subject to an overall channel count of 16 channels. The settings are:-
 - Bundle number: This sets the bundle address of each transmitter. The bundle numbers are 0 (off, ie no transmission), 1-255 are multicast, 256-65279 are unicast and 65280-65535 are private.
 - Priority: This sets the priority of the transmitter. If bandwidth resources are limited, then audio will be transmitted in order of priority.
 - Unicast mode: If the transmitter bundle address is normally unicast (>255), but more than one receiver is available for that bundle address, then the bundle can be transmitted either multicast or multi-unicast.
 - Max Unicast: Depending on unicast mode, the maximum number of multi-unicast bundles can be set between 1 and 4.
 - TX1...TX4: This lists the four transmitters associated with the bundle address and allows the user to set the audio subchannels associated with that bundle. A Cobranet CM2 type interface can have up to 16 audio channels, numbered 1-16. The subchannel mapping allows the user to decide which of the 16 audio channels are mapped to each bundle and in which order they are transmitted.

- Resolution: This sets the word length of the transmitted audio to 16, 20, or 24 bit. Note: if the word depth is set to 24bit, then only 7 audio channels can fit in one bundle.
- Transmitter format settings: The options are 1.33mS, 2.66mS or 5.33mS latency. Note: there are significant trade-offs if changes are made to the 5.33mS default settings (see PM25). Also note that the MTS amplifiers uses all 16 Cobranet channels of the CS496xxx chipset, so 96kHz operation is not possible.
- Receiver setup: This section covers the Cobranet receivers. The CS496xxx chipset allows for up to 8 receivers, each of up to 8 channels, subject to an overall channel count of 16 channels. The settings are:-
 - Bundle number: Same process and limitations as described in the transmitter section
 - Priority: Same process and limitations as described in the transmitter section
 - Receiver active: This LED only lights if there is a valid transmitter sending audio on that bundle address.
 - RX1...RX8: Same process and limitations as described in the transmitter section
- Cobranet status: As follows:-
 - Conductor status: LED lights up, if the amplifier is the Conductor.
 - Conductor priority: Default is 32. Change the value to increase or decrease the possibility of this interface becoming the Conductor
 - Error count: Running total of Cobranet errors detected.
 - Last error code: The Cobranet error code of the last error detected.
 - Status LED's: Link shows Ethernet link status. Tx and Rx shows data transfer. Bridge/Local shows serial bridge status.

Note 1: To enter a value in any of the setting boxes, overwrite the existing value and then press "Enter"/"Return". If "Enter"/"Return" is not pressed then the value is not stored.

Note 2: "Update" gets the current values from the amplifier NOT sends values to the amplifier.

Note 3: See below for Unicast/Multicast/Multi-Unicast operation

- If Unicast mode = A (ie always Multicast) and MaxUnicast = 0, then the bundle is always Multicast
- If Unicast mode = A (ie always Multicast) and MaxUnicast = 1, then the bundle is always Multicast above 1 Multi-Unicast bundle
- If Unicast mode = A (ie always Multicast) and MaxUnicast = 2, then the bundle is always Multicast above 2 Multi-Unicast bundles
- If Unicast mode = A (ie always Multicast) and MaxUnicast = 3, then the bundle is always Multicast above 3 Multi-Unicast bundles
- If Unicast mode = A (ie always Multicast) and MaxUnicast = 4, then the bundle is always Multicast above 4 Multi-Unicast bundles

- If Unicast mode = N (ie never multicast) and MaxUnicast = 1, then the Multi-Unicast is limited to 1 bundle and receiver priority will determine access.
- If Unicast mode = N (ie never multicast) and MaxUnicast = 2, then the Multi-Unicast is limited to 2 bundles and receiver priority will determine access.
- If Unicast mode = N (ie never multicast) and MaxUnicast = 3, then the Multi-Unicast is limited to 3 bundles and receiver priority will determine access.
- If Unicast mode = N (ie never multicast) and MaxUnicast = 4, then the Multi-Unicast is limited to 4 bundles and receiver priority will determine access.

Note 1: When Unicast = N and MaxUnicast is set to 0, this is a null setting and MaxUnicast is actually set to 1 as default.

Note 2: All Cobranet settings need up to 1 minute to establish persistence, as they are stored in the cobranet flash. If the amplifier power is cycled before the settings are stored to flash, then the settings will be lost.

3.3.2.4 Amplifier settings

The Amplifier settings tab is shown in Figure 3.6 below. The operation is very similar to the VBUSMON software, as it uses the same dataset.

Note that the Gain settings does not have directly number entry, but clicking above or below the slider will increase or decrease the slider in 0.5dB increments.

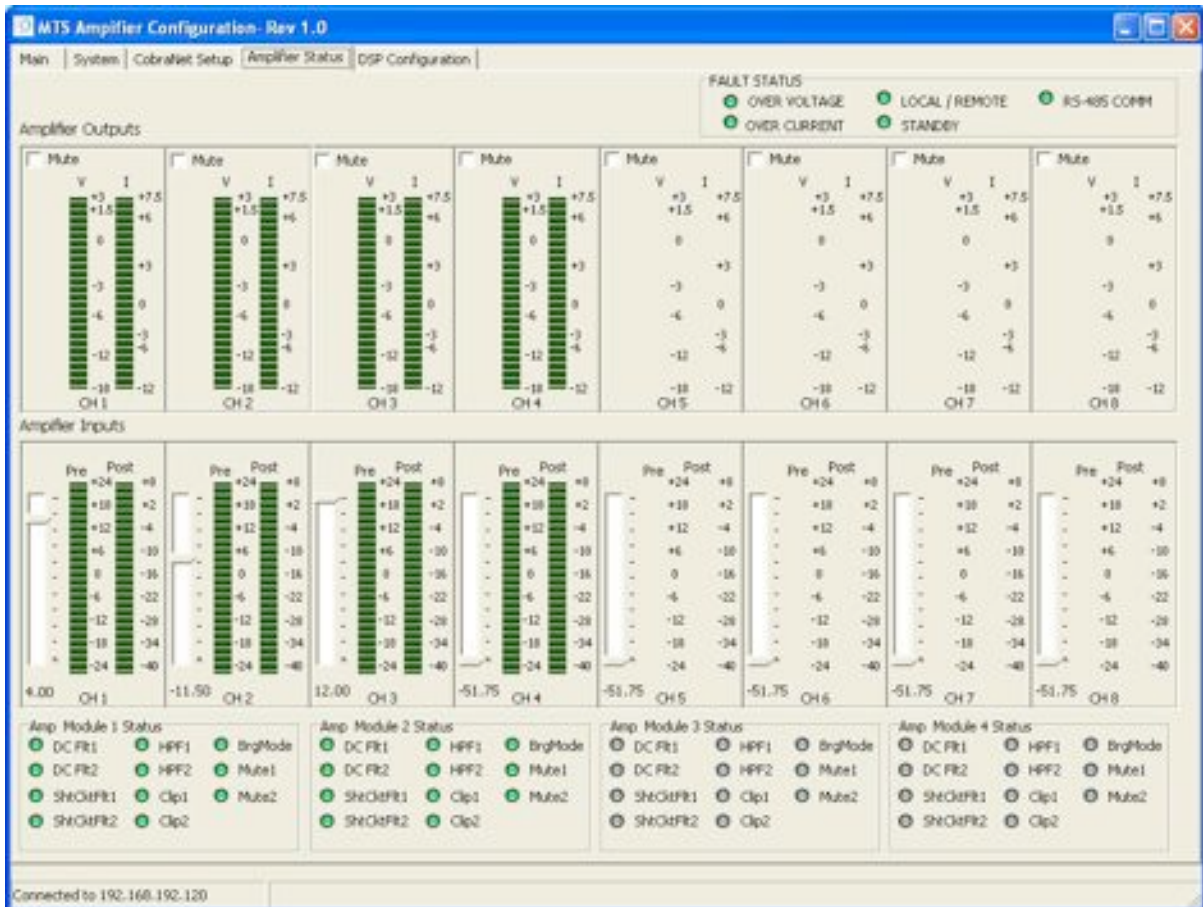

Figure 3.6: Amplifier settings tab.

The metering will only show those modules present. In Figure 3.6, the amplifier was a COM3004, so only 2 modules, ie 4 channels are present.

The output voltage and current metering is displayed slightly differently to VBUSMON, ie dB above or below nominal clip instead of absolute volts and amps. 0dB volts will be the level at which the amplifier is still below activating the internal compressor. 0dB amps is the nominal maximum current draw into 4 ohms. +6dB would be the nominal maximum current draw into 2 ohms. Above +6dB, it is likely that the over-current limit will be triggered and the amplifier will self protect.

The rest of the parameters and settings follows VBUSMON, as detailed in section 2.9.3.

3.3.2.5 DSP settings

The final configuration tab is for the DSP inside the COM series amplifiers- see Figure 3.7 below.

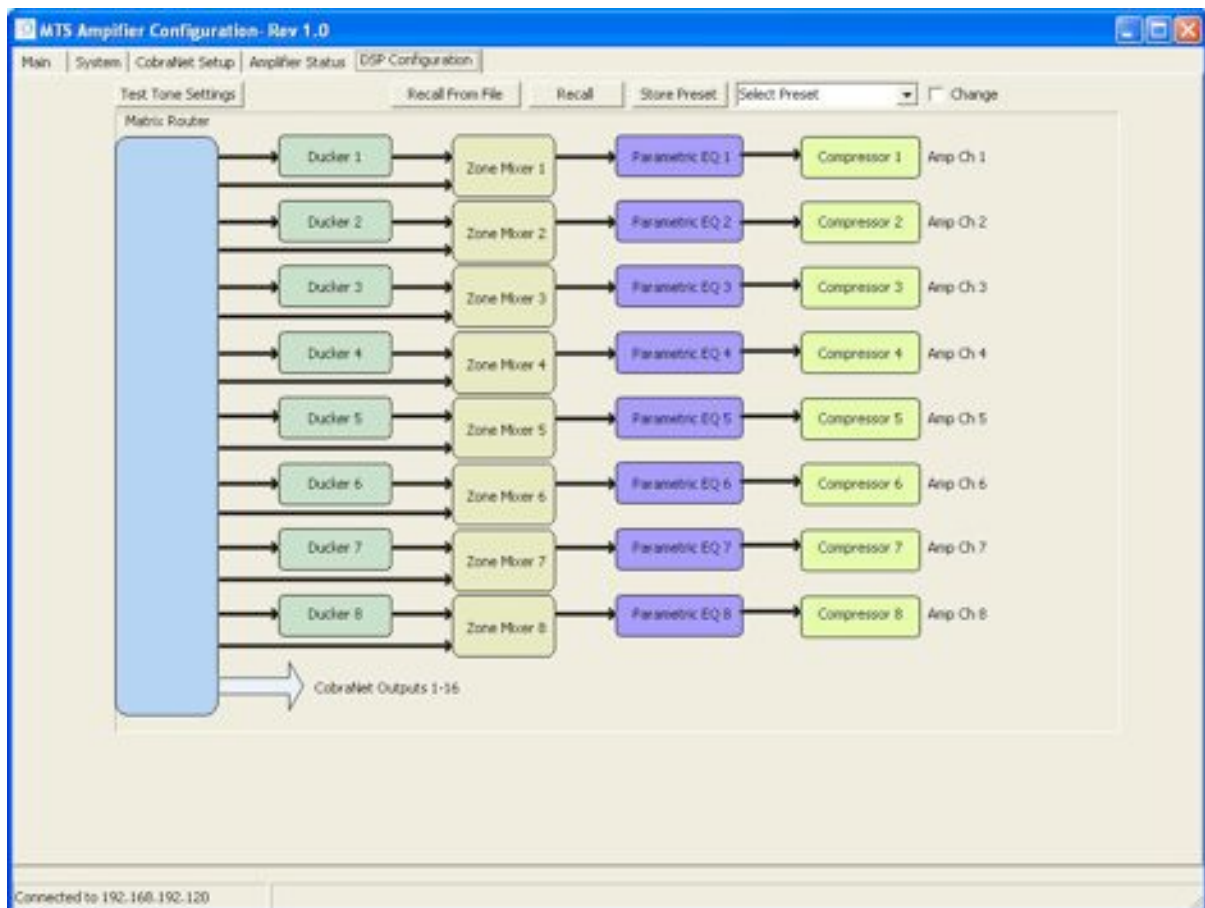



Figure 3.7: DSP configuration tab.

The first 4 tabs can be used to setup any SI and/or COM series amplifier in terms of System, CobraNet and Amplifier parameters, but the DSP section only refers to the COM series DSP.

4 Amplifier Vacuum Fluorescent Display

The front panel features a 16 character, 2 line Vacuum Fluorescent Display (VFD). The display provides a convenient way of checking the internal settings and values of key parameters inside the amplifier. Although it is possible to set certain important values via the VFD (eg, IP address, bundle address, etc), this is not intended as a substitute to using the Host processor, as it would be unrealistically tedious to try and configure each amplifier via the VFD.

The colors used in each section below indicate a certain type of data to be displayed, ie...

-  Block color in Red indicates alphanumeric value
-  Block color in Blue indicates solid block or bargraph indicator

Data entry is done as follows...

- Press Up/Down to move between Menu's
- Press Select to start setting the value
- Press Up/Down to set the first 0-9 digit.
- Press select again to move to the next digit
- Repeat until the last digit is set
- Press Menu to complete the process.

4.1 Cobranet Status

There are three cobranet status screens.

4.1.1 Cobranet Communication Status

On powerup, the VFD will display the message "Initializing Hardware..." and then show the Cobranet status screen as indicated in Figure 4.1a and b below.

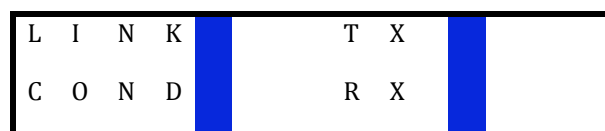

Figure 4.1a: Status Screen A

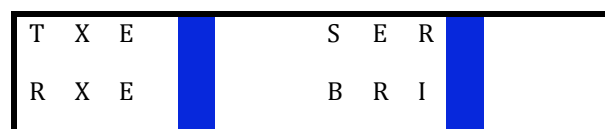

Figure 4.1b: Status Screen B

Where:-

- LINK = Ethernet link activity
- SER = Activity at Cobranet RS485 serial port

- BRI = Serial Bridging. Off is local RS485 control of the amplifier, On is serial bridging (either simple serial bridge or remote control of the amplifier host processor via serial bridging)
- TX, RX are On when transmitting or receiving audio bundles (audioTxChannel and audioRxChannel in PM25)
- TXE, RXE are transmit and receive errors-see programmers manual PM25 section 8.1.1

4.1.2 Conductor Status

Figure 4.2 below shows the Conductor status. The top line shows the conductor priority status. Default is 32. VFD settings range from 1 (least likely be conductor) to 255 (most likely to be conductor).



Figure 4.2: Conductor Status

The Name entry displays the Alphanumeric product name embedded inside the Cobranet Firmware.

4.1.3 Serial Port Options

Figure 4.3a and b below shows the setting of the RS485 serial port. There are 3 settings that can be made from the VFD in screen 4.3a:

- Local: This enables the use of the Cobranet serial port to control the amplifier from a Host Processor
- Remote: This enables remote control of the amplifier variables (only) over the network and by a host processor connected to the serial port on a remote cobranet device.
- Bridge: This enables serial bridging, for use as a serial communications channel, over the network.

Screen 4.3b can set the following...

- Master: Used with Remote to enable local control of a remote amplifier via the local serial port.
- Slave: Used with “Remote” to enable remote control of the local amplifier over serial bridging and “Local” to enable local serial control of the amplifier.
- Serial address: Set in decimal and can have valid values between 96 (0x60) and 127 (0x7F).

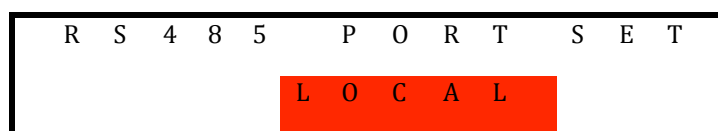

Figure 4.3a: Serial Port settings

M	O	D	E	M	A	S	T	E	R
A	D	D	R	E	S	S	9	6	

Figure 4.3b: Serial Port settings

Screens 4.3c and 4.3d are used to set the baud rate for the Internal (I-BUS) and external (V-BUS) serial buses. In general they should be set to the same speed and use the default setting of 115200. If a particularly long connection cable is used and the control is unstable, then the speed of both buses can drop to 38400.

I	-	B	U	S	B	A	U	D	R	A	T	E
					1	1	5	2	0	0		

Figure 4.3c: Internal Serial Port settings

V	-	B	U	S	B	A	U	D	R	A	T	E
					1	1	5	2	0	0		

Figure 4.3d: External Serial Port settings

4.1.4 Cobranet Errors

Figure 4.4 below shows any cobranet errors monitored (see PM25). The top line shows the current error and the bottom line shows the past 4 errors.

C	N	E	R	R	O	R	S	1	2	3	4
0	0	0	0	0	0			0	0		

Figure 4.4: Cobranet Errors

4.1.5 Interface Firmware

Figure 4.5 below shows the following information

- Cobranet firmware revision xx.yy.zz
- Cobranet chipset (currently CS 496121 16 x 16 channels)
- MTS amplifier firmware revision x.y.z
- RS485 port address in decimal. The RS485 port address is settable from the VFD (Note: The RS485/Cobranet DIP switch at the rear of the amplifier must be set to Cobranet).

C	2	.	1	1	.	6	4	9	6	1	2	1
M	1	.		0	.	7	4	8	5	1	2	7

Figure 4.5: Interface Firmware revision details

4.2 Bundle Addressing

Figure 4.6 below shows one of six VFD screens to set bundle addresses. The first two set Transmitters 1&2 and 3&4 respectively. The next four set Receivers 1&2, 3&4... 7&8 respectively.

C		T	X	U	6	5	5	3	5	U	6	5	5	3	4
S		1	2	M	1					M	2				

Figure 4.6: Bundle address settings for Transmitters 1 & 2.

The settings are:-

- “TX” or ‘RX” indicates that the VFD is looking at a pair of bundle transmitters (TX) or receivers (RX).
- “12” indicates that the VFD is looking at bundles 1&2. There are 4 possible transmitters (1&2, 3&4) and 8 possible receivers (1&2... 7&8).
- “S” indicates “Stored” bundle address. Bundle addresses are persistent, so the amplifier will power up with a stored bundle address (Factory default is 00, ie off).
- “C” indicates “Current” bundle address, if it has been changed from the stored bundle address.
- “M” at the start of the TX bundle address indicates that the bundle is transmitted Multicast.
- “U” at the start of the TX bundle address indicates that the bundle is transmitted Unicast or Multi-Unicast.
- Valid bundle address values are 0-65535

4.3 IP addressing

Figures 4.6 and 4.7 below show the VFD screens used to set the IP addresses for the Cobranet and Ethernet ports respectively.

C	N		P	O	R	T		I	P		A	D	D	R
1	9	2	.	1	6	8	.	1	9	2	.	1	0	1

Figure 4.6: Cobranet Port IP address

E	C		P	O	R	T		I	P		A	D	D	R
1	9	2	.	1	6	8	.	1	9	2	.	1	0	0

Figure 4.7: Ethernet Port IP address

The default value of the Cobranet IP address is 0.0.0.0, as Cobranet does not need an IP address to pass audio traffic. To take control of the Cobranet port, set the IP address to the desired setting. The Cobranet IP address will be persistent, so any setting will be stored during a power cycle.

The Ethernet port has a factory default address of 192.168.192.100. This can be changed using the VFD. Note: the amplifier will attempt to use DHCP to obtain an IP address on power up. If the port does not obtain an IP address within 1 minute, then it will revert to the embedded IP address, either factory default or the user setting (if one has been made).

Both IP addresses are set in the same way.

- Press Select to start setting the value
- Press up/down to set the first 0-9 digit.
- Press select again to move to the next digit
- Repeat until the last digit is set
- If a digit does not need to be changed, then simply press select again.
- Press Menu to exit.

4.4 Signals

The signals are metrics taken in the analog domain. The input signals are pre and post the input section VCA. This allows the user to optimally condition the input to the A-D converter.

The output signals are the real time voltage and current measurements taken at the output of the amplifier.

In each case, the full scale of the display is the peak value of the signal.

4.4.1 Input Signals

There are eight consecutive screens for the eight possible input channels. Figure 4.8 shows the screen display for Channel 1.



Figure 4.8: Input signals for Channel 1.

The "<" indicates pre-VCA and ">" indicates post VCA. Channels 2... 8 are identical. In the case of amplifiers with less than 8 channels, then screens for the unused channels will show no signal.

4.4.2 Output Signals

There are also eight consecutive screens for the eight possible output channels. Figure 4.9 shows the screen display for Channel 1.



Figure 4.9: Output signals for Channel 1.

The “V” indicates Voltage and “C” indicates Current. Channels 2... 8 are identical. In the case of amplifiers with less than 8 channels, then screens for the unused channels will show no signal.

4.5 Amplifier settings

There are 4 screens to monitor and set parameters in the analog section of the amplifier

4.5.1 Gain

There are two VFD screens to monitor and set the Gain, see Figure 4.10.

A	T	T	1	+	1	2	2	+	0
			3	+	1	2	4	-	5 1

Figure 4.10: Gain for Channels 1-4.

The first screen sets channels 1-4 and the second screen sets channels 5-8. The gain can range from to -84dB to +12dB

4.5.2 Temperature

There is one VFD screen to monitor amplifier module temperature, see Figure 4.11.

T	1	2	+	2	5	3	4	+	2	5
C	5	6	+	2	5	7	8	+	2	6

Figure 4.11: Amplifier module Temperature.

The temperature is given in degrees C. Normal operation will range between room temperature and +65degC. At 75degC the amplifier module will switch off due to over temperature.

In the case of amplifiers with less than 8 channels, then screens for the unused channels will show no signal.

4.5.3 Mute & Fault status

There are two VFD screens to monitor channel mute and fault, see Figure 4.12.

M	1	2	3	4
F	1	2	3	4

Figure 4.12: Mute and Fault status for Channels 1-4.

The first screen monitors channels 1-4 and the second screen monitors channels 5-8. The Mute panel will show the mute status of that channel and the fault panel will come on in the event of DC and/or Over-current.

4.5.4 HPF & Bridge settings

There are two VFD screens to monitor channel HPF and Bridge settings, see Figure 4.13.

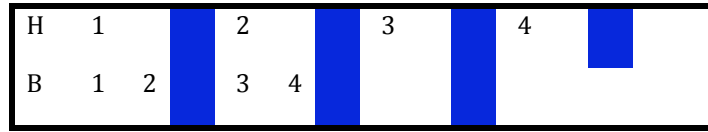

Figure 4.13: HPF and Bridge status for Channels 1-4.

The first screen monitors channels 1-4 and the second screen monitors channels 5-8. The HPF panel will show the status of the rear panel HPF switch and the Bridge panel will show the status of the rear panel bridge switch. Note: in the case of COM and PAG amplifier models, there is no bridge switch, as these are 70/100volt models.